

**V.A.G Service.**

---

**Workshop Manual**  
**Audi 80 1987 ▶ , Audi 90 1987 ▶**

Engine Code letters	3B								
<b>Booklet</b>		Motronic injection and ignition system							

**Edition 01.91**

---

**VAG**

---

**Service Department. Technical Information**



01 Self diagnosis, electrical check	Page
- Motronic self-diagnosis	01-1
- Fault memory interrogation and reset with V.A.G 1551 fault reader	01-5
- Final control diagnosis with V.A.G 1551 fault reader	01-11
- Checking diagnosis plug wiring	01-16
- Fault table	01-17
- Basic adjustment of engine with V.A.G 1551	01-48
- Removing and installing Motronic control unit, connecting V.A.G 1598 test box	01-57
24 Motronic injection system	Page
Servicing Motronic injection system	24-1
- Technical data	24-4
- Rules for cleanliness	24-5
- Safety measures	24-6
Motronic components	24-8
- Checking system and holding pressures	24-11
- Checking fuel pump relay and operating signal	24-19
- Checking injectors	24-23
- Checking idle speed and CO Content	24-31
- Checking idle stabilization	24-33
- Checking Lambda probe and Lambda control	24-38
- Removing and installing Lambda probe	24-41
- Checking solenoid valve activated charcoal filter	24-42
- Checking solenoid for boost pressure limitation	24-46
- Checking and adjusting idle switch	24-51
- Checking and adjusting throttle valve potentiometer	24-54
- Checking altitude sensor	24-57
- Checking air volume meter	24-60
Vacuum connections	24-67
28 Ignition system	Page
Motronic components	28-1
- Technical data, ignition	28-4
- Safety measures for Motronic	28-7
- Checking ignition output stage	28-9
- Checking ignition coil	28-11
- Checking ignition timing sensor	28-13
- Checking engine speed sensor	28-15
- Checking intake air temperature sensor	28-18
- Renewing intake air temperature sensor	28-19
- Checking coolant temperature sensor	28-20
- Checking voltage supply for Motronic control unit	28-21
- Checking knock sensors	28-22
- Checking Hall sender	28-25
- Basic distributor setting	28-27
- Ignition cable routing	28-33

## MOTRONIC SELF-DIAGNOSIS (SD)

### Self-diagnosis technical data:

<u>Memory</u>		
• Permanent memory	yes	
• Volatile memory	no	
<u>Data output</u>		
• Rapid data transmission	yes	
• Supplementary flash code output at CARB lamp	no	
<u>Final control element diagnosis</u>		yes
<u>Basic engine setting</u>		yes
<u>Test evaluation block readout</u>		no
<u>Individual test data readout</u>		no
<u>Component installation location</u>	see Repair Group 24	

The Motronic control unit (J 220) is equipped with self-diagnosis. If malfunctions occur in the monitored sensors or components, they are recorded along with an indication of the fault type in the fault memory.

In addition, sporadic malfunctions are identified as such.

Malfunctions which only occur occasionally are classified as sporadic faults.

01-1

After data evaluation, the Motronic control unit proceeds to distinguish between 31 different kinds of malfunctions - see Fault Table, page 01-17 - and stores these until the contents of the fault memory are erased.

In addition, the Motronic control unit is also equipped with final control element diagnosis for 8 final control elements, page 01-11.

#### Note:

- Final control element diagnosis can only be performed with engine off.
- In contrast, fault memory readout should be performed with engine running if possible.

The SD possibilities can only be fully utilized in conjunction with V.A.G 1551 fault memory reader.

In Repair Group 01 only operating mode 1 with the V.A.G 1551 is described.

#### Notes on fault recognition:

- If a fault condition remains for longer than a specific period it is stored as a permanent fault. If the malfunction should disappear for a period of time, it is classified it as a sporadic fault. This procedure is repeated on a continuing basis.

01-2

- The reclassification of a fault from permanent to sporadic only takes place when the malfunction remains absent for a specific period.
- If the fault fails to reappear in the course of the next 50 engine starts, this sporadic fault is erased automatically.

Test conditions

- Fuse 21 OK
- Fuel pump relay OK

Check engine earth connections

Before fault memory readout, final control element diagnosis, wiring test or component replacement are performed, the following earth connections are to be checked for corrosion and/or faulty contact and repaired as necessary:

- Electronics earth lead -1-
- Power earth lead -2-

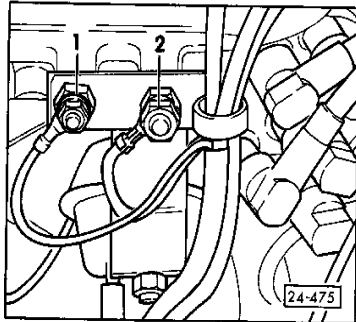

01-3

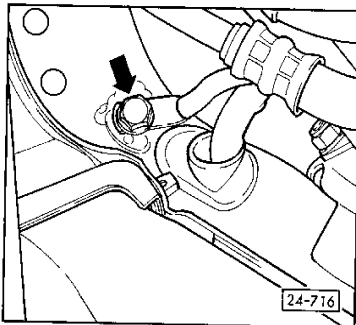

- Attachment point for battery earth strap on body.

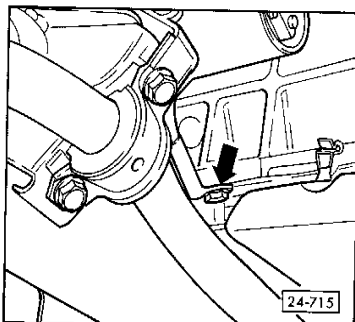

- Attachment point for earth strap between engine and right-side side member.

01-4

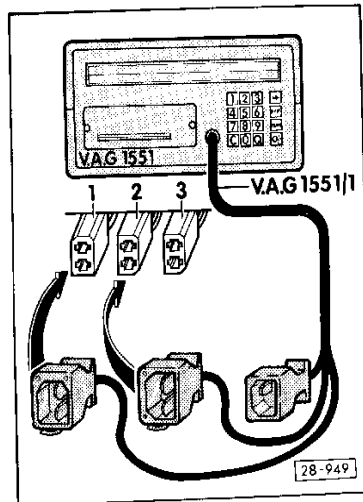

V.A.G - Self diagnosis    HELP  
 1- Rapid data transmission  
 2- Flash code display\*

FAULT MEMORY INTERROGATION AND RESET WITH V.A.G 1551 FAULT READER

Note test conditions - page 01-3.

Note:  
 The fault reader can only be erased after readout has been performed.

- \* - Connect V.A.G 1551/1 fault reader with diagnosis lead to the diagnosis plugs in the drivers side footwell as follows.
  - Black plug to black diagnosis socket.
  - White plug to brown diagnosis socket.
  - Blue plug is not required.
- Voltage supply is via Fuse 21.
- Press C key on V.A.G 1551.

\* Display:  
 appear alternately

- Notes:
- Additional operating instructions are provided by the HELP key V.A.G 1551.
  - The - key is used for switching to the next step in the program.

01-5

- Allow engine to run, or, alternately, use starter to crank engine for approx. 5 sec. without switching off the ignition afterwards.
- Use Print key to turn on printer (indicator lamp in key lights up).
- Press Key 1 for "rapid data transmission" operation mode.

Rapid data transmission    HELP  
 Enter address word    XX

\* Display:

- Press keys 0 and 1. (Address word "engine electronics" is entered with 01).

Rapid data transmission    Q  
 01 Engine electronics

\* Display:

- Confirm entry with Q key.

01-6

895907404 ENGINE →  
Code 1

Control unit does not respond!  
HELP

- ◀ The control unit identification and the code are shown in the display.

◀ Shown in the display:

- Press the HELP key for a list of possible fault causes.
- After the possible fault causes have been rectified, enter the address word 01 for "engine electronics" and confirm with the Q key.

Note:

If "Control unit does not respond" is still displayed after rectification of possible fault causes,

- Check diagnosis plug leads -1- black and -2- brown - page 01-16.
- See fault table, -, page 01-17 under flash code 65535 - control unit fault!

- Press → key.

◀ Display:

Note:

When the HELP key is pressed a list of possible functions is printed.

- Press keys 0 and 2 (02 is used to select the "Fault memory recall" function).

01-7

Rapid data transmission HELP  
Select function XX

Rapid data transmission Q  
02 - Fault memory recall

X Fault registered!

oder

No fault registered!

- Press keys 0 and 2. (02 selects the "Fault memory recall" function).

◀ Display shows:

- Confirm entry with Q key.

◀ The display shows the number of faults stored or "No faults registered".

- Press - key.

The faults stored are displayed consecutively and printed out - Fault table - page 01-17.

◀ Note:

Fault code 00513, engine rpm sensor, and fault code 00532, supply voltage, are not always displayed with ignition on and engine running. This fault display is of no significance under these conditions. The fault is significant after an unsuccessful attempt to start the engine (engine fails to start) without the ignition being subsequently switched off.

- After display of last fault/no fault registered, press - key.

Note:

If a malfunction is present but is not recognized by the self-diagnosis, perform further diagnosis with the aid of "Engine Fault Finding" binder.

01-8

Rapid data transmission      HELP  
Select function      XX

◀ Display:

- Press keys 0 and 5.  
(05 cancels the fault memory).

Rapid data transmission      Q  
05 - Cancel fault memory

◀ Display:

- Confirm entry with Q key.

Caution!  
Fault memory not recalled

◀ Is shown in display:

Note:

- \* If the ignition is switched off or the engine is run, for instance, between the fault memory recall and fault memory cancellation stages, the fault memory is not cancelled.
- Procedure must be performed in precise sequence, i.e. begin with fault memory enquiry.

01-9

Rapid data transmission  
Fault memory cancelled

◀ Display:

- Repair faults listed in print-out using fault table - page 01-17.
- Recall and cancel fault memory. (This cancels any faults that might be stored during repair, for instance, when a plug is disconnected.)
- Perform road test of at least 5 minutes duration.
- Check by performing another fault memory recall.

01-10



FINAL CONTROL ELEMENT DIAGNOSIS WITH V.A.G 1551

Note:

During the final control element diagnosis, all injectors, the idle stabilization valve, the solenoid for the activated charcoal filter and the boost pressure limiter solenoid are checked acoustically or by contact. The injectors are only activated 5 times for 2 ms. Background noise should be avoided for the acoustic injector check as the switching noise (clicking) of the injectors is very quiet and brief.

Final control element diagnosis is interrupted if engine is started or an rpm pulse is detected.

Final control element activation sequence:

Injector Cylinder 1 -N30  
 Injector Cylinder 2 -N31  
 Injector Cylinder 4 -N33  
 Injector Cylinder 5 -N83  
 Injector Cylinder 3 -N32  
 Idle stabilization valve -N71  
 Solenoid valve 1 for activated charcoal canister -N80  
 Boost pressure limiter solenoid -N75

01-11

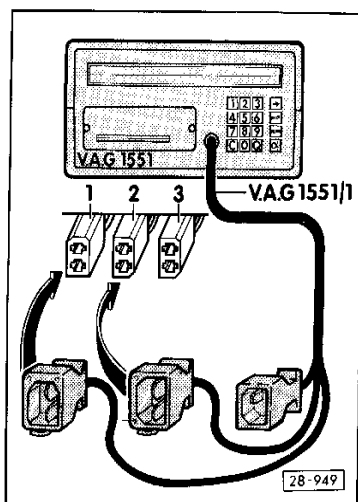

◀ Connect V.A.G 1551/1 fault reader with diagnosis lead to the diagnosis sockets in the driver's side footwell as follows.

- Black plug to black diagnosis socket -1-.
- White plug to brown diagnosis socket -2-.
- Blue plug is not required.
- Voltage supply is via Fuse 21.

◀ - Press C key on V.A.G 1551.

Display:

\* appear alternately

- Switch on ignition.
- Use print key to turn on printer (control light lamp lights up in key).
- Press key 1 for "Rapid data transmission" operational mode.

01-12

Rapid data transmission HELP  
Enter address word XX

◀ Display:

- Press keys 0 and 1.  
(Use 01 to enter the address word "Engine electronics").

Rapid data transmission Q  
01 - Engine electronics

◀ Display:

- Confirm entry with Q key.

895907404 ENGINE →  
Code 1

◀ Control unit identification and code are shown in the display:

◀ Appears in display:

- See page 01-7.
- Press key.

Control unit does not respond!  
HELP

◀ Display:

Note:

A list of possible functions is printed when the HELP key is pressed.

Rapid data transmission HELP  
Select function XX

01-13

- Press keys 0 and 3.  
(Use 03 to select "Final control element" function).

Rapid data transmission Q  
03 - Final control element diagnosis

◀ Display:

- Confirm entry with Q key.

Final control element diagnosis  
Injector, cylinder 1 -N30

◀ Display:

- Lift throttle control lever briefly. As soon as the idle position is regained, the injector for Cylinder 1 clicks five times. The control unit then switches automatically to the next injector (note display on V.A.G 1551).
- If the control unit is to be switched to the following injector without being checked, the - key should be pressed.
- All injectors are to be checked consecutively in this way.
- Press - key.

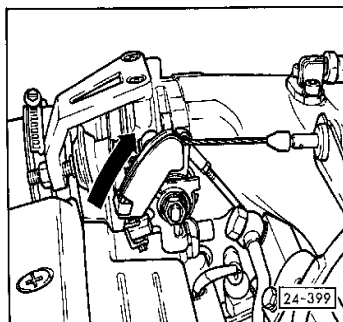

Final control element diagnosis →  
Idle stabilization valve -N71

◀ Display:

This valve is actuated (clicks) until the next final control element is selected by pressing the - key.

01-14

Final control element diagnosis →  
Solenoid valve for activated charcoal cannister -N80

◀ Display:  
This valve is activated (clicks) until the next final control element is activated by pressing the key.

Final control element diagnosis  
Solenoid valve for boost pressure limitation -N75

◀ Display:  
This valve is activated (clicks) until the final element control diagnosis is terminated by pressing the key.

Rapid data transmission HELP  
Select function XX

◀ Display:  
- The final control element diagnosis can be repeated by again selecting function 03 "Final control element diagnosis". Should one of the valves fail to click check valve/control - see Repair Group 24.

01-15

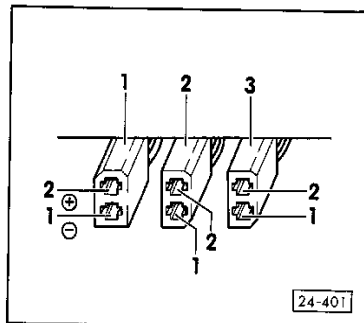

CHECKING DIAGNOSIS SOCKET WIRING

- The diagnosis sockets are located in the footwell on the driver's side.

◀ Diagnosis socket -1- black (Voltage supply)

Contact 1 connected to earth  
Contact 2 Positive (Terminal 15 via Fuse 21)

Use V.A.G 1526 handmultimeter to check wiring for continuity:

- Switch off ignition.
- Connect V.A.G 1598 test box - page 01-57.

Diagnosis socket -2- brown (Rapid data transmission)

Diagnosis socket Contact	-J220 or V.A.G 1598 socket
1	13
2	55

01-16

FAULT TABLE

- The following is a listing of all possible faults which can be recognized by the Motronic control unit -J220 according to fault code. Faults which may be present are printed out according to fault code (5-digit) and flash code (4-digit) only when the printer for V.A.G 1551 is switched on.
- Only the fault codes are listed in the fault table.
- If the engine is switched off between road test and fault memory recall, all of the faults stored are displayed as "sporadic fault" only.
- If faults only occur occasionally or if the fault memory is erased after the malfunction has been rectified, these faults are also displayed as "sporadic faults". The letters "SP" appear at the right of the display on V.A.G 1551.
- If components are found to be defective, the cables to the components should also be checked for short circuits and open circuits using the Current Flow Diagram.
- Before rectifying fault or renewing components, check Motronic control unit -J220 earth connections at contacts 10, 14, 19 and 24 (Specification: max. 0.5 ohm) as well as engine earth contacts for corrosion and damage, check fuel pump relay - Repair Group 24.
- Removal of plugs from electronic components with ignition switched can result in malfunctions being stored in the fault memory. For this reason, plugs should only be removed from electronic components with the ignition switched off.
- After fault memory recall/fault repair, the basic engine settings should be checked using V.A.G 1551 - see page 01-48.

01-17

Output at printer of V.A.G 1551	Possible fault sources	Possible effects	Fault elimination
00000 No fault recognized	Where malfunction is present: Fault not recognized by self-diagnosis	_____	Continue diagnosis using fault table in binder "Engine fault finding".
00000 Recall end	_____	_____	_____

01-18

Output at printer of V.A.G 1551	Possible fault sources	Possible effects	Fault elimination
<u>00513</u> Engine rpm sensor -G28 * Implausible signal * No signal  * Mechanical fault	<ul style="list-style-type: none"> <li>- Metal chips on -G28.</li> <li>- Base socket of -G28 loose.</li> <li>- Distance from -G28 to ring gear of flywheel greater than 1.2 mm.</li> <li>- Broken teeth on ring gear of flywheel.</li> <li>- Open circuit between 3-pin plug in engine compartment and -G28.</li> <li>- Open circuit between -J220 and -G28.</li> <li>- Short circuit between contact 47 and -J220/screening or engine earth screening.</li> <li>- Open circuit in screening of -G28.</li> <li>- 3-pin plug connection from -G28 and -G4 in engine compartment reversed.</li> <li>- -G28 defective.</li> <li>- Input for -G28 in -J220 defective (-J220 defective).</li> </ul>	<ul style="list-style-type: none"> <li>- Engine does not start.</li> <li>- Ignition miss.</li> <li>- Engine stalls.</li>   <li>- Engine does not start.</li> </ul>	<ul style="list-style-type: none"> <li>- Check -G28 - page 28-15.</li> <li>- Remedy short circuit and open circuit using CFD.</li>   <li>- Connect plugs at -G4 and -G28 correctly.</li> </ul>

\* One of these displays is shown in addition to the relevant component.

01-19

Output at printer of V.A.G 1551	Possible fault sources	Possible effects	Fault elimination
<u>00514</u> Ignition timing sensor -G4 * No signal	<ul style="list-style-type: none"> <li>- Base socket of -G4 loose.</li> <li>- Distance from -G4 to pin on ring gear of flywheel greater than 1.2 mm.</li> <li>- Pin of flywheel bent or broken off.</li> <li>- Open circuit between 3-pin plug in engine compartment and -G4.</li> <li>- Open circuit between -J220 and -G4.</li> <li>- Short circuit between Contact 49 and -J220 or screening or engine earth.</li> <li>- Open circuit in screening of -G4.</li> <li>- 3-pin plug connections from -G4 and -G28 in the engine compartment reversed.</li> <li>- -G4 defective.</li> <li>- Input for -G4 in -J220 defective (-J220 defective).</li> </ul>	<ul style="list-style-type: none"> <li>- Fault before engine start; Engine does not start.</li> <li>- Fault after engine start or start attempt.</li>   <li>- Engine does not start.</li> </ul>	<ul style="list-style-type: none"> <li>- Check -G4 - page 28-13.</li>   <li>- Remedy short circuit and open circuit according to CFD.</li> </ul>

\* This display is shown in addition to the relative component.

01-20

Output at printer of V.A.G 1551	Possible fault sources	Possible effects	Fault elimination
<u>00515</u> Hall sender -G40 * Open/short circuit to positive * Short circuit to earth * Mechanical fault	- No voltage supply for -G40 from -J220. - No earth for -G40. - Open in signal wire to -J220 or short to earth in signal wire. - Short circuit between Contact 8 and 12 at -J220. - Open circuit between 3-pin plug connection in engine compartment and -J220. - Position of -G4 pin. - -G40 defective. - Input for -G40 at -J220 defective (-J220 defective). - Toothed belt jumped.  - Basic distributor setting. - Pin of -G4.	- Engine does not start.  - Power loss.	- Check -G40 - page 28-25. - Remedy short circuit and open circuit according to CFD.  - Check toothed belt - Repair Group 15. - Check -G40 - page 28-25. - Basic distributor adjustment - page 28-27. - Check pin of -G4 - page 28-13.

\* One of these displays is shown in addition to the relevant components.

Note on flash code 00515:  
Ignore fault if it is displayed as sporadic fault!

01-21

Output at printer of V.A.G 1551	Possible fault sources	Possible effects	Fault elimination
<u>00516</u> Idle switch -F60 * Open/short circuit to positive * Short circuit to earth	- Adjustment -F60. - Throttle valve sticking. - Throttle damper sticks/adjusted incorrectly. - Footmat presses on accelerator. - Throttle cable adjustment - Open circuit to Contact 52 from -J220. - Input for -F60 at -J220 defective (-J220 defective). - Contact 52 from -J220 short to earth. - Moisture in throttle valve plug.	- Idle regulation switches to control.  - Idle speed not in specified range.	- Check -F60 - page 24-51. - Check throttle damper - see Repair Group 20.  - Adjust throttle cable - Repair Group 20. - Remedy short circuit according to CFD. - Remedy short circuit.

\* One of these displays is shown in addition to the relevant component.

01-22

Output at printer of V.A.G 1551	Possible fault sources	Possible effects	Fault elimination
<u>00518</u> Throttle valve potentiometer -G69 * Open/short circuit to earth * Short circuit to positive	<ul style="list-style-type: none"> <li>- Short circuit to positive in -G69 or in connecting wiring between -G69 and Contact 53 of -J220.</li> <li>- Short circuit to earth in -G69 or in wiring between -G69 and Contact 53 of -J220.</li> <li>- -G69 defective.</li> <li>- -J220 defective.</li> <li>- Moisture or corrosion in socket at -G69.</li> </ul>	<ul style="list-style-type: none"> <li>- Specified boost pressure not achieved.</li> <li>- Reduced power.</li> </ul>	<ul style="list-style-type: none"> <li>- Check -G69 - page 24-54.</li> </ul>

\* One of these displays is shown in addition to the relative component.

01-23

Output at printer of V.A.G 1551	Possible fault sources	Possible effects	Fault elimination
<u>00522</u> Coolant temperature sensor -G62 * Short circuit to earth * Open/short circuit to positive	<ul style="list-style-type: none"> <li>- Short circuit to earth.</li> <li>- Moisture in plug of -G62.</li> <li>- Open circuit between -G62 and -J220.</li> <li>- Contact resistance between -G62 and -J220.</li> <li>- -G62 defective.</li> <li>- Input from -G62 at -J220 defective (-J220 defective).</li> </ul>	<ul style="list-style-type: none"> <li>- Cold start difficulties at extremely low temperatures.</li> <li>- Operating faults during warm-up.</li> </ul>	<ul style="list-style-type: none"> <li>- Check -G62 - page 28-20.</li> </ul>

\* One of these displays is shown in addition to the relevant component.

01-24

Output at printer of V.A.G 1551	Possible fault sources	Possible effects	Fault elimination
<u>00523</u> Intake air temperature sensor - G42 * Short circuit to earth * Open/short circuit to positive	<ul style="list-style-type: none"> <li>- Short circuit to earth.</li> <li>- Open circuit between -G42 and Contact 44 of -J220.</li> <li>- -G42 defective.</li> <li>- Input from -G42 at -J220 defective (-J220 defective).</li> </ul>	<ul style="list-style-type: none"> <li>- Slight power reduction.</li> <li>- Increased fuel consumption.</li> </ul>	<ul style="list-style-type: none"> <li>- Check -G42 - page 28-18.</li> </ul>

\* One of these displays is shown in addition to the relevant component.

01-25

Output at printer of V.A.G 1551	Possible fault sources	Possible effects	Fault elimination
<u>00524</u> Knock sensor 1 -G61 * No signal	<ul style="list-style-type: none"> <li>- Plug/socket corrosion.</li> <li>- -G61 loose.</li> <li>- Open circuit or short circuit between -G61 and -J220.</li> <li>- Short circuit between -G61 and earth or to screening.</li> <li>- -G61 defective.</li> <li>- Input for -G61 at -J220 defective (-J220 defective).</li> </ul>	<ul style="list-style-type: none"> <li>- High fuel consumption.</li> <li>- Reduced power.</li> <li>- Boost pressure not achieved.</li> </ul>	<ul style="list-style-type: none"> <li>- Repair contacts.</li> <li>- Torque 20 Nm.</li> <li>- Remedy open circuit and short circuit.</li> </ul>

\* One of these displays is shown in addition to the relevant component.

01-26



Output at printer of V.A.G 1551	Possible fault sources	Possible effects	Fault elimination
<u>00525</u> Lambda probe -G39 • Short circuit to positive • No signal • Short circuit to earth	<ul style="list-style-type: none"> <li>- Open circuit to -J220.</li> <li>- Probe heater not functioning.</li> <li>- Fuse -S25 (probe heater) defective.</li> <li>- Heat element in probe defective.</li> <li>- Probe heater wiring.</li> <li>- Short circuit to earth in signal wire.</li> <li>- Short circuit in signal wire to screening.</li> <li>- Fuel tank empty, min. 10 l.</li> <li>- Fuel system pressure.</li> <li>- Defective spark plug, plug connector, ignition cable, distributor cap or rotor.</li> <li>- Air leak behind -G70.</li> <li>- Leakage in exhaust system before catalyst.</li> <li>- Lambda probe defective.</li> <li>- Earth reference wire from Contact 10, -J220 to engine lock open.</li> </ul>	<ul style="list-style-type: none"> <li>- Exhaust gas not OK.</li> <li>- Increased fuel consumption.</li> <li>- Black smoke.</li> <li>- Spark plugs fouled.</li> <li>- Lambda regulation switches to control.</li> </ul>	<ul style="list-style-type: none"> <li>- Remedy open circuit.</li> <li>- Check Lambda probe heater - page 24-38.</li> <li>- Check basic engine setting with V.A.G 1551 - page 01-48.</li> </ul>

\* One of these displays is shown in addition to the relevant component.

01-27

Output at printer of V.A.G 1551	Possible fault sources	Possible effects	Fault elimination
<u>00528</u> Altitude sensor -F96 • Open/short circuit to positive • Short circuit to earth	<ul style="list-style-type: none"> <li>- Short circuit to positive in -F96 or in wiring between -F96 and Contact 46 of -J220.</li> <li>- Short circuit to earth in -F96 or in wiring between -F96 and Contact 46 of -J220.</li> <li>- -F96 defective.</li> <li>- Input for -F96 at -J220 defective (-J220 defective).</li> </ul>	<ul style="list-style-type: none"> <li>- Reduced power.</li> <li>- Boost pressure not achieved.</li> </ul>	<ul style="list-style-type: none"> <li>- Check -F96.</li> <li>- Check altitude sensor (-F96) - page 24-57.</li> <li>- Check boost pressure - Repair Group 21.</li> </ul>

\* One of these displays is shown in addition to the relevant component.

01-28

Output at printer of V.A.G 1551	Possible fault sources	Possible effects	Fault elimination
<u>00532</u> Voltage supply * Signal too large * Signal too small	<ul style="list-style-type: none"> <li>- Voltage supply greater than 16 V.</li> <li>- Alternator defective.</li> <li>- Engine start with two batteries in series.</li> <li>- Poor earth connection to -J220.</li> <li>- Battery discharged.</li> <li>- Current draw with ignition switched off.</li> </ul>	<ul style="list-style-type: none"> <li>- Destruction of -J220.</li> <li>- Idle speed not within specified range.</li> <li>- Voltage below 6 volts.</li> <li>- Engine does not start.</li> </ul>	<ul style="list-style-type: none"> <li>- Check voltage.</li> <li>- Check battery charge.</li> <li>- Check -J220 - page 28-21.</li> </ul>

\* One of these displays is shown in addition to the relevant component.

Note on fault code 00532:

Ignore display if the fault is displayed as a sporadic fault!  
 This fault can be stored if the engine is run at idle for long periods with a number of electrical consumers operating, resulting in battery discharge, or if the starter was not operated before the fault memory recall, with only the ignition switched on.

01-29

Output at printer of V.A.G 1551	Possible fault sources	Possible effects	Fault elimination
<u>00533</u> Idle control * Adaptation limit exceeded * Adaptation limit not achieved	<ul style="list-style-type: none"> <li>- -N71 jams.</li> <li>- -G70 characteristic curve displaced.</li> <li>- Contact resistance at plug of -N71.</li> <li>- -N71 jams open.</li> <li>- -G70 characteristic curve displaced.</li> <li>- Outside air between -G70 and -N71.</li> </ul>	<ul style="list-style-type: none"> <li>- Idle speed too low</li> <li>- Idle speed too high</li> </ul>	<ul style="list-style-type: none"> <li>- Check -N71 - page 24-33.</li> <li>- Check -G70 - page 24-60.</li> <li>- Repair leak.</li> </ul>

\* One of these displays is also shown.

01-30

Output at printer of V.A.G 1551	Possible fault sources	Possible effects	Fault elimination
<u>00537</u> Lambda control * Control limit exceeded * Control limit not achieved	<ul style="list-style-type: none"> <li>- Fuel tank empty, min. 10 l.</li> <li>- Fuel system pressure too low.</li> <li>- Defective spark plugs, plug connectors, distributor cap or rotor.</li> <li>- Outside air behind -G70.</li> <li>- Exhaust system lead upstream of catalyst.</li> <li>- Lambda probe defective.</li> <li>- Fuel system pressure excessive.</li> </ul>	<ul style="list-style-type: none"> <li>- CO upstream of catalyst less than 0.3%.</li> <li>- Increased fuel consumption.</li> <li>- Black smoke.</li> <li>- Spark plug fouling.</li> <li>- CO upstream of catalyst greater than 1%.</li> </ul>	<ul style="list-style-type: none"> <li>- Refuel vehicle.</li> <li>- Repair leak.</li> <li>- Check Lambda probe - page 24-38.</li> <li>- Check fuel system pressure - page 24-11.</li> </ul>

\* One of these displays is also shown.

01-31

Output at printer of V.A.G 1551	Possible fault sources	Possible effects	Fault elimination
<u>00540</u> Knock sensor 2 -G66 * No signal	<ul style="list-style-type: none"> <li>- Plug/socket corrosion.</li> <li>- -G66 loose.</li> <li>- Open or short circuit between -G66 and -J220.</li> <li>- Short circuit between -G66 and earth or to screening.</li> <li>- -G66 defective.</li> <li>- Input for -G66 at -J220 defective (-J220 defective).</li> </ul>	<ul style="list-style-type: none"> <li>- Excessive fuel consumption.</li> <li>- Reduced power.</li> <li>- Boost pressure not achieved.</li> </ul>	<ul style="list-style-type: none"> <li>- Tightening torque 20 Nm.</li> <li>- Repair open circuit and short circuit.</li> </ul>

\* This display is shown in addition to the relevant component.

01-32

Output at printer of V.A.G 1551	Possible fault sources	Possible effects	Fault elimination
<u>00543</u> Maximum engine speed exceeded * Signal too large	- Engine overrevved. (e.g. incorrect gear selection).	- Possible engine damage.	

Note on fault code 00543:  
Maximum engine speed exceeded is stored as a fault when 7440 rpm has been exceeded. This engine speed can only be exceeded through driver error (e.g. shifting error).

\* This display is also shown.

01-33

Output at printer of V.A.G 1551	Possible fault sources	Possible effects	Fault elimination
<u>00544</u> Maximum boost pressure exceeded * Signal too large	- Outside air downstream of turbocharger. - Dump valve fault. - Boost pressure limiting solenoid -N75 defective. - Vacuum line between inlet manifold and -J220 leaking or disconnected. - Pressure sensor in Motronic control unit - J220 defective.	- Bad misfiring under full load. - Boost pressure excessive.	- Check connections. - Check dump valve - Repair Group 21. - Check solenoid valve for boost pressure limitation -N75 - page 24-46.

\* This display is also shown.

01-34

Output at printer of V.A.G 1551	Possible fault sources	Possible effects	Fault elimination
<u>00553</u> Air volume sensor -G70 * Signal too large * Signal too small	<ul style="list-style-type: none"> <li>- Open circuit between -G70 and -J220.</li> <li>- Voltage supply to -G70 open or short to earth.</li> <li>- Short circuit to earth in signal wire to Contact 7 of -J220.</li> <li>- Short circuit in signal wire to Contact 7 of -J220.</li> <li>- -G70 defective.</li> <li>- Input for -G70 at -J220 defective (-J220 defective).</li> </ul>	<ul style="list-style-type: none"> <li>- Limp home.</li> <li>- Poor accelerator response.</li> <li>- Reduced power.</li> <li>- Misfiring during acceleration.</li> <li>- Engine may also stall after start or on overrun.</li> </ul>	<ul style="list-style-type: none"> <li>- Check -G70 - page 24-60.</li> </ul>

\* One of these displays will also be shown in addition to the relevant component.

01-35

Output at printer of V.A.G 1551	Possible fault sources	Possible effects	Fault elimination
<u>00561</u> Mixture control * Adaptation limit exceeded * Adaptation limit not achieved	<ul style="list-style-type: none"> <li>- Fuel system pressure too low.</li> <li>- Defective spark plugs, plug connectors, ignition wires, distributor cap or rotor.</li> <li>- Outside air downstream of -G70.</li> <li>- Exhaust system leak upstream of catalyst.</li> </ul>	<ul style="list-style-type: none"> <li>- Increased fuel consumption.</li> <li>- Black smoke.</li> <li>- Spark plugs fouled.</li> </ul>	<ul style="list-style-type: none"> <li>- Refuel vehicle.</li> <li>- Repair leak.</li> <li>- Check fuel system pressure - page 24-11.</li> </ul>

\* One of these displays is also shown.

01-36

Output at printer of V.A.G 1551	Possible fault sources	Possible effects	Fault elimination
<u>00575</u> Intake manifold pressure * Signal too small * Signal too large * Control discrepancy	<ul style="list-style-type: none"> <li>- Vacuum pipe between intake manifold and -J220 open, blocked, kinked or crushed.</li> <li>- Fluid separator in hose between intake manifold and -J220 full of fluid.</li> <li>- Dump valve faulty.</li> <li>- Boost pressure limiting solenoid valve -N75 defective.</li> <li>- Pressure sensor in Motronic control unit - J220 defective.</li> <li>- Turbocharger faulty.</li> </ul>	<ul style="list-style-type: none"> <li>- Reduced power.</li> </ul>	<ul style="list-style-type: none"> <li>- Check/drain vacuum line and fluid separator.</li> <li>- Check boost pressure limiting solenoid - N75 - page 24-46.</li> <li>- Check turbo charger - Repair Group 20.</li> </ul>

\* One of these displays is also shown.

01-37

Output at printer of V.A.G 1551	Possible fault sources	Possible effects	Fault elimination
<u>00577</u> Cylinder 1 knock control	<ul style="list-style-type: none"> <li>- Knock control module in - J220 defective (-J220 defective).</li> <li>- Poor fuel quality, less than 91 RON.</li> <li>- Signal wire from -G28 or -G4 open or reversed at -J220.</li> <li>- Applies only to cylinder displayed.</li> <li>- Abnormal engine noises (auxiliary units loose).</li> <li>- Open circuit in screening of -G61.</li> </ul>	<ul style="list-style-type: none"> <li>- High fuel consumption.</li> <li>- Reduced power.</li> </ul>	<ul style="list-style-type: none"> <li>- Replace -J220.</li> <li>- Use fuel with at least 91 RON.</li> </ul>
<u>00578</u> Cylinder 2 knock control		<ul style="list-style-type: none"> <li>- Maximum speed not achieved.</li> </ul>	<ul style="list-style-type: none"> <li>- Check signal wire from -G28 and -G4 with CFD - page 28-15 and 28-13.</li> </ul>
<u>00579</u> Cylinder 3 knock control * Control limit exceeded		<ul style="list-style-type: none"> <li>- Reduced boost pressure.</li> </ul>	<ul style="list-style-type: none"> <li>- Repair open circuit.</li> </ul>

\* This display is also shown.

Note:

\* The ignition angle retardation from knock control always applies to the cylinder displayed only.

01-38

Output at printer of V.A.G 1551	Possible fault sources	Possible effects	Fault elimination
<u>00580</u> Cylinder 4 knock control  <u>00581</u> Cylinder 5 knock control  * Control limit is exceeded	<ul style="list-style-type: none"> <li>- Knock control module in - J220 defective (-J220 defective).</li> <li>- Poor fuel quality, less than 91 RON.</li> <li>- Signal wire from -G28 or -G4 open or reversed at -J220.</li> <li>- Applies only to cylinder displayed.</li> <li>- Abnormal engine noises (auxiliary units loose).</li> <li>- Open circuit in screening of -G66.</li> </ul>	<ul style="list-style-type: none"> <li>- High fuel consumption.</li> <li>- Reduced power.</li> <li>- Maximum speed not achieved.</li> <li>- Reduced boost pressure.</li> </ul>	<ul style="list-style-type: none"> <li>- Replace -J220.</li> <li>- Use fuel with at least 91 RON.</li> <li>- Check signal wire from -G28 and -G4 with CFD - page 28-15 and 28-13.</li> <li>- Repair open circuit.</li> </ul>

\* This display is also shown.

Note:

- The ignition angle retardation from knock control always applies to the cylinder displayed only.

01-39

Output at printer of V.A.G 1551	Possible fault sources	Possible effects	Fault elimination
<u>01247</u> Solenoid 1 for activated charcoal container -N80  * Short circuit to positive  * Open/short circuit to earth	<ul style="list-style-type: none"> <li>- Short circuit to positive in -N80 or in connection between -N80 and Contact 5 of -J220.</li> <li>- Short circuit to earth in -N80 or in connection - N80 and Contact 5 to -J220.</li> <li>- Fuse 24 defective.</li> <li>- Open circuit.</li> </ul>	<ul style="list-style-type: none"> <li>- Poor transitional response at moderate throttle openings.</li> <li>- Possible smell of petrol from vehicle.</li> <li>- Idle speed.</li> </ul>	<ul style="list-style-type: none"> <li>- Check -N80 - page 24-42.</li> </ul>

\* One of these displays is shown in addition to the component.

01-40

Output at printer of V.A.G 1551	Possible fault sources	Possible effects	Fault elimination
<u>01249</u> Injector Cylinder 1 -N30 * Open short circuit to earth * Short circuit to positive	- Short circuit to earth. - Open circuit. - Fuse 28 defective. - Short circuit to positive at plug or in injector.	- Engine runs roughly or stalls.	- Check injectors - page 24-23.

\* One of these displays is shown in addition to the component.

01-41

Output at printer of V.A.G 1551	Possible fault sources	Possible effects	Fault elimination
<u>01250</u> Injector Cylinder 2 -N31 * Open short circuit to earth * Short circuit to positive	- Short circuit to earth. - Open circuit. - Fuse 28 defective. - Short circuit to positive at plug or in injector.	- Engine runs roughly or stalls.	- Check injectors - page 24-23.

\* One of these displays is shown in addition to the component.

01-42



Output at printer of V.A.G 1551	Possible fault sources	Possible effects	Fault elimination
<u>01251</u> Injector Cylinder 3 -N32 * Open short circuit to earth * Short circuit to positive	<ul style="list-style-type: none"> <li>- Short circuit to earth.</li> <li>- Open circuit.</li> <li>- Fuse 28 defective.</li> <li>- Short circuit to positive at plug or in injector.</li> </ul>	<ul style="list-style-type: none"> <li>- Engine runs roughly or stalls.</li> </ul>	<ul style="list-style-type: none"> <li>- Check injectors - page 24-23.</li> </ul>

\* One of these displays is shown in addition to the component.

01-43

Output at printer of V.A.G 1551	Possible fault sources	Possible effects	Fault elimination
<u>01252</u> Injector Cylinder 4 -N33 * Open short circuit to earth * Short circuit to positive	<ul style="list-style-type: none"> <li>- Short circuit to earth.</li> <li>- Open circuit.</li> <li>- Fuse 28 defective.</li> <li>- Short circuit to positive at plug or in injector.</li> </ul>	<ul style="list-style-type: none"> <li>- Engine runs roughly or stalls.</li> </ul>	<ul style="list-style-type: none"> <li>- Check injectors - page 24-23.</li> </ul>

\* One of these displays is shown in addition to the component.

01-44

Output at printer of V.A.G 1551	Possible fault sources	Possible effects	Fault elimination
<u>01253</u> Injector Cylinder 5 -N83 * Open short circuit to earth * Short circuit to positive	<ul style="list-style-type: none"> <li>- Short circuit to earth.</li> <li>- Open circuit.</li> <li>- Fuse 28 defective.</li> <li>- Short circuit to positive at plug or in injector.</li> </ul>	<ul style="list-style-type: none"> <li>- Engine runs roughly or stalls.</li> </ul>	<ul style="list-style-type: none"> <li>- Check injectors - page 24-23.</li> </ul>

\* One of these displays is shown in addition to the component.

01-45

Output at printer of V.A.G 1551	Possible fault sources	Possible effects	Fault elimination
<u>01257</u> Valve for idle stabilization -N71 * Short circuit to positive * Open/short circuit to earth	<ul style="list-style-type: none"> <li>- Short circuit to positive in -N71 or in wiring between -N71 and Contact 4 of -J220.</li> <li>- Short circuit to earth in -N71 or in wiring between -N71 and Contact 4 or -J220.</li> <li>- Fuse 24 defective.</li> <li>- Open circuit.</li> </ul>	<ul style="list-style-type: none"> <li>- Deviation in engine speed from specification at engine operating temperature.</li> <li>- Engine can stall when cold.</li> <li>- Poor drivability at part throttle (jerking).</li> <li>- Flat spot during acceleration or engine runs roughly.</li> <li>- Idle speed 1100 - 1200 rpm on limp home.</li> </ul>	<ul style="list-style-type: none"> <li>- Check -N71 - page 24-33.</li> </ul>

\* One of these displays is shown in addition to the component.

01-46

Output at printer of V.A.G 1551	Possible fault sources	Possible effects	Fault elimination
<u>01262</u> Solenoid valve for boost pressure limiting -N75 * Short circuit to positive * Open/short circuit to earth	- Short circuit to positive in -N75 or in wiring between -N75 and Contact 23 of -J220. - Short circuit to earth in -N75 or in wiring between -N75 and Contact 23 of -J220. - Fuse 24 defective. - Open circuit.	- Boost pressure too high. - Boost pressure too low. - Bad misfiring under full load.	- Check -N75 - page 24-46.
<u>65535</u> Control unit defective	- Earth connection to -J220 Contacts 10, 14, 19 and 24. - Control unit defective. - With ignition on - no voltage at Contact 37 of -J220.	- Engine fails to start.	- Consult CFD to check earth connection.

\* One of these displays is shown in addition to the component.

Note:

- Before eliminating faults or renewing components, check earth connections to -J220, Contact 10, 14, 19 and 24 (Specification: max. 0.5 ohm) as well as earth points on engine for corrosion or damage, check fuel pump relay - see page 24-19.
- When fault is eliminated, clear fault memory, carry out road test and recall fault memory again.

01-47

BASIC SETTING OF ENGINE WITH V.A.G 1551

Requirements:

- Minimum engine temperature: 85° C
- All electrical consumers switched off
- Air conditioning off

- Test drive for at least five minutes avoiding stopping for traffic lights where possible.

- Recall fault memory - page 01-5.

Note:

Do not switch off engine after fault memory recall.

- Let engine continue to idle.

◀ Display:

Note:

When the HELP key is pressed a summary of possible functions is printed out.

- Press key 0 and 4.  
(04 is used to select function "Initiate basic setting").

Rapid data transmission HELP	
Select function	XX

01-48

Rapid data transmission Q  
04 Initiate basic setting

- ◀ Display:
  - Confirm with Q key.

Initiate basic setting HELP  
Display group number XX

- ◀ Display:  
Note:  
When the HELP key is pressed the procedure for entering display group number is printed out.
  - Press 0 key twice.  
(00 selects "System at basic setting").
  - Confirm entry with Q key.

System at basic setting  
1 2 3 4 5 6 7 8 9 10

- ◀ Display:
  - Wait at least 5 sec. before comparing display information with the code explanation - page 01-51.

Note:

- The figures shown in display fields 1 through 10 are provided in decimal form. Where required, calculations for conversion to physical form are found in column "Corresponds to measurements" - see page 01-51.
- Within 5 minutes after road test and fault memory recall, the display in field 9 should be compared to the specification - see page 01-51. Long periods at idle can cause specification to be exceeded without a fault being present.

01-49

- The display in field 10 represents the ignition angle calculated by the control unit -J220. In case of lower power output, check whether the marking on camshaft sprocket and TDC mark on flywheel coincide correctly - see Repair Group 13.
- When the printer is switched on the current display is printed out on a printer tape.
- The current display is printed out each time the print key is pressed.
- If specified values are achieved in all the display fields.

- Press → key.

Rapid data transmission HELP  
Select function XX

- ◀ Display:
  - Press keys 0 and 6.  
(06 selects the function "End recall").

Rapid data transmission Q  
06 End recall

- ◀ Display:
  - Confirm entry with Q key.

Rapid data transmission HELP  
Enter address word XX

- ◀ Display:

01-50

Explanation of codes for display fields 1 through 10

Display field	Display specifica-	Corresponds to measurement	Designation	Remarks
1	184 - 215	85° - 105° C	Current engine temperature	Requirement for all other displays/specified values
2	20 - 24		Current engine load	Air conditioning off, without consumers
3	77 - 83	770 - 830/rpm	Current engine load	Air conditioning off, without consumers
4	121 - 135		Idle speed stabilization operating range	Air volume change through -N71
5	70 - 125		Idle speed stabilization characteristic curve 0.	Internal calculation value
6	123 - 137		Idle speed stabilization - Load adjustment	Air volume change through -N71
7	41 - 61		Idle speed stabilization - Characteristic curve control	Internal calculation value
8	123 - 133		Lambda control	After approx. 1.5 min.
9	115 - 165		Lambda adjustment	If display is high, repeat road test
10	35 - 37	8 - 12° BTDC	Current ignition angle	Ignition angle calculated by -J220

\* Note: If the displays do not correspond with the specified values, check that air conditioner is switched off. If air conditioner is switched off, see test table page 01-52.

01-51

Check Table

The following table shows the checks to be carried out if the displays do not coincide with the specified values.

Note: Ensure that air conditioner and air conditioner compressor are switched off before testing.

Display field	Display	Fault source	Fault elimination
1	greater than 215	Sender for coolant temperature -G62	<ul style="list-style-type: none"> <li>- Check -G62 - page 28-20</li> <li>- Recall fault memory - page 01-5.</li> </ul>
1	less than 184	Thermostat Sender for coolant temperature -G62	<ul style="list-style-type: none"> <li>- Check thermostat - Repair Group 19.</li> <li>- Check -G62 - page 28-20.</li> <li>- Recall fault memory - page 01-5.</li> </ul>
2	greater than 24	Air conditioner switched on Electrical consumers switched on Lambda control Lambda probe Air conditioner compressor is running despite air conditioner being switched off Air volume sensor -G70 Central hydraulic pump Outside air between turbocharger and throttle valve	<ul style="list-style-type: none"> <li>- Switch off air conditioner</li> <li>- Switch off consumers</li> <li>- Lambda control, check display field 8.</li> <li>- Check Lambda probe - page 24-38.</li> <li>- Check air conditioner - Repair Group 87.</li> <li>- Check -G70 - page 24-60.</li> <li>- Check central hydraulic pump - Repair Group 48.</li> <li>- Investigate cause of air leak.</li> </ul>

01-52

Display field	Display V.A.G 1551	Fault source	Fault elimination
2	less than 20	Air leak between air volume sensor -G70 and turbo charger Outside air downstream of throttle valve Vacuum hose disconnected Fuel pressure regulator  Crankcase breather leak Fuel tank breather  Solenoid 1 for activated charcoal cannister jams  Air volume sensor -G70	- Determine fault source.  - Determine fault source. - Check vacuum system. - Check system and holding pressure - page 24-11. - Check crankcase sealing. - Check fuel tank breather system - page 24-40. - Perform final control element diagnosis - page 01-11. - Check -G70 - page 24-60.
3	greater than 83	Valve for idle speed stabilization -N71 at lower control stop  Air leak downstream of throttle valve, injector or vacuum hose disconnected (intake manifold rear - see page 24-2, position 20/page 24-67). Air conditioner  Air conditioner compressor signal present although compressor switched off Valve for idle speed stabilization	- Briefly press accelerator 4 times at intervals of 15 seconds. - Remedy fault source.  - Check air conditioner - see Repair Group 87.  - Perform final control element diagnosis - page 01-11.

01-53

Display field	Display	Fault source	Fault elimination
3	less than 77	Valve for idle speed stabilization -N71 jams Air conditioner compressor operates without signal to Motronic unit -J220  Valve for idle speed stabilization -N71	- Check -N71 - page 24-33. - Check air conditioner - see Repair Group 87. - Perform final control element diagnosis - page 01-11.
4	less than 121	Outside air downstream of throttle valve  Valve for idle speed stabilization -N71 jams	- Remedy fault source.  - Check -N71 - page 24-33.
4	greater than 135	Air conditioner compressor operationing although air conditioner switched off  Battery charge	- Check air conditioner - Repair Group 87. - Check battery charge.
5	less than 70	Valve for idle speed stabilization -N71	- Check -N71 - page 24-33.
5	greater than 125	Outside air to valve for idle speed stabilization Valve for idle speed stabilization -N71	- Remedy fault source. - Check -N71 - page 24-33.
6	not between 123-137	Control for valve for idle speed stabilization -N71  Outside air	- Accelerate briefly and watch display, display must be between 123 and 137. - Determine fault source.

01-54

Display field	Display	Fault source	Fault elimination
7	less than 41 greater than 61	Valve for idle speed stabilization -N71 Outside air	- Check -N71 - page 24-31. - Determine fault source.
8	constant 128	Fuel level too low Lambda probe	- Min. 10 l fuel in tank. - Check Lambda control - see page 24-38.
8	not between 123 and 133	Lambda adjustment Lambda probe Outside air to air volume sensor -G70 Fuel system pressure Leaks in exhaust system	- Check display field 9. - Check Lambda probe - see page 24-38. - Rectify fault. - Check system pressure - see page 24-11. - Check - Repair Group 26.
8	jumps	Fuel level too low	- Min. 10 l fuel in tank.
9	less than 115	Fuel system pressure Air volume sensor -G70 Lambda probe Outside air between turbo charger and throttle valve	- Check system pressure - see page 24-11. - Check -G70 - see page 24-60. - Check Lambda probe - see page 24-38. - Determine fault source.

01-55

Display field	Display	Fault source	Fault elimination
9	165 or greater	Fuel level too low Outside air between turbocharger and air volume sensor/intake manifold	- Min. 10 l fuel in tank. Remedy air leak source.
10	38 or greater	Valve for idle speed stabilization -N71 Idle switch -F60	- Perform final control element diagnosis - page 01-11. - Check -N71 - page 24-33. - Check -F60 - page 24-15.
10	34 or less	Valve for idle speed stabilization -N71	- Perform final control element diagnosis - page 01-11. - Check -N71 - page 24-33.
10	jumps	Outside air at injectors Spark plugs	- Rectify fault. - Check spark plugs.

01-56

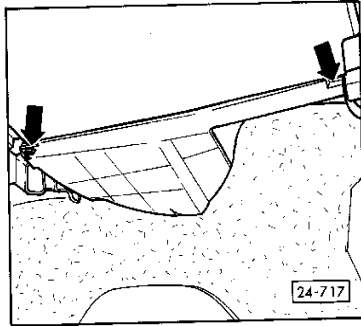

REMOVING AND INSTALLING MOTRONIC CONTROL UNIT.  
CONNECTING V.A.G 1598 TEST BOX

- Switch off ignition.
- ◀ - Remove cover beneath glove box.

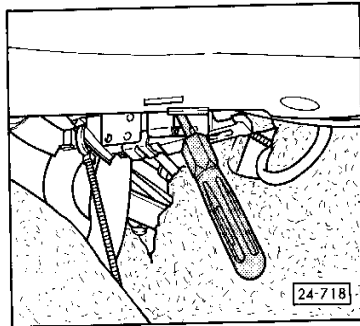

- Fold back carpet below Motronic control unit.
- ◀ - Insert screwdriver between Motronic control unit support bracket and plastic duct next to retaining clip.
- Screwdriver can be rotated slightly to unsnap retaining clips on carrier plate above retaining clips from the recesses in the plastic duct.
- Lower control unit somewhat and remove screwdriver.
- Pull control unit downward 3 ... 4 cm. The control unit snaps into place second recess in this position (service position).

01-57

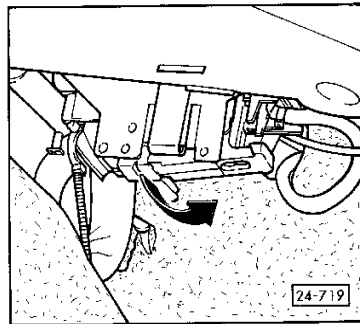

- ◀ - Wait at least 30 sec. after switching off ignition, then unlock and release plug from Motronic control unit. In this position the V.A.G 1598 test box with V.A.G 1598-5 adapter can be connected to Motronic control unit or engine cable for testing. The vacuum line remains connected.

Note:  
 The additional steps only need to be performed if the Motronic control unit is to be removed completely.

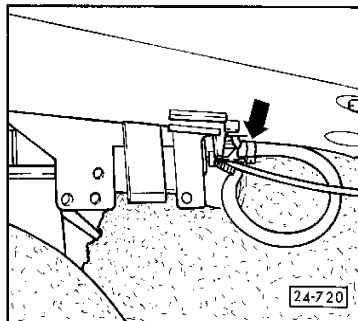

- ◀ - Remove hose clamp from vacuum line. Pull off vacuum line.
- Use screwdriver to release snap as described on previous page. Carefully pull control unit downward and out of recess. On vehicles with air conditioner, the condensation hose must carefully be pushed to the side to prevent it being damaged by the side flange of the control unit (remove hose if necessary).

01-58



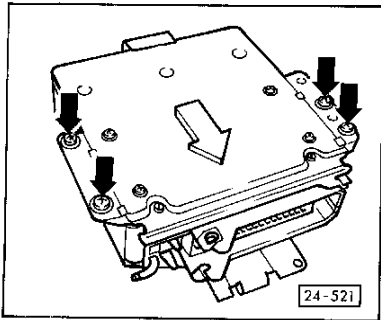

**Note:**  
Ensure the vacuum line is not damaged when control unit is removed.

- ◀ - Unscrew Motronic control unit from carrier plate.

- The Motronic control unit is installed in reverse sequence.

**Note:**

- Ensure that lines are not kinked during installation.
- Vacuum line runs from Motronic control unit to fluid separator behind insulating material, and then to engine compartment.

**Important!**  
It is imperative that the plug to the Motronic control unit not be connected with ignition on.

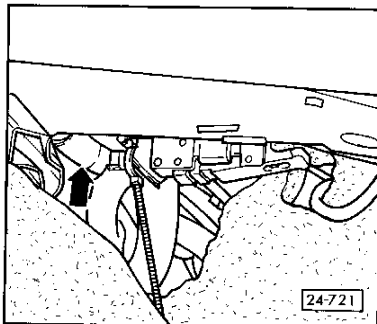

- Note:**
- ◀ On vehicles with air conditioning ensure that the condensation drain hose is connected before reinstalling cover below glove box (arrow).

**SERVICING MOTRONIC FUEL INJECTION SYSTEM**

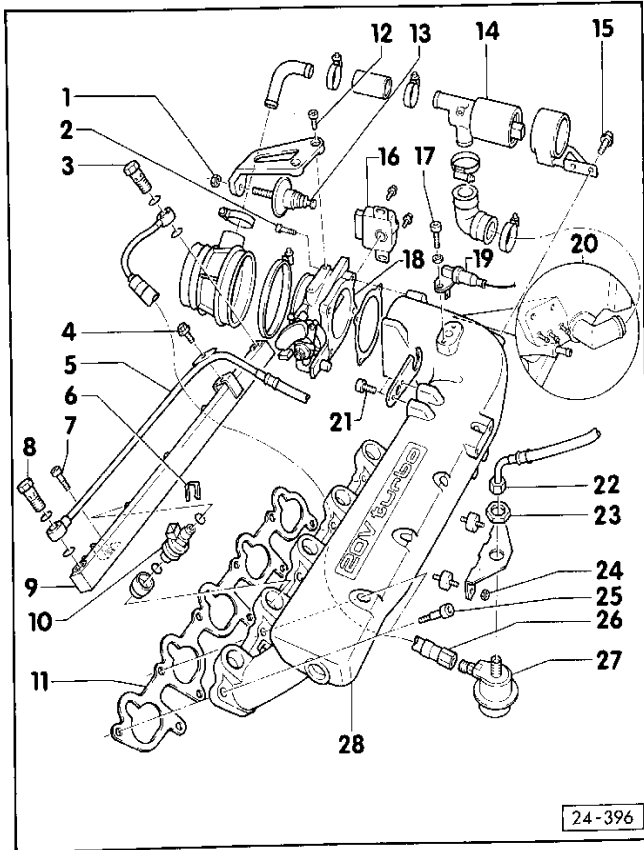

**Important!**

- Before carrying out repair work on the fuel injection system always perform fault memory recall and final control element diagnosis.
- Always renew all seals and gaskets.

- Recall fault memory - see page 01-5
- Final control element diagnosis - see page 01-11

**Note:**

Always renew seals and gaskets.

- 1- 10 Nm
- 2- 10 Nm
- 3- Banjo bolt 25 Nm
- 4- 10 Nm
- 5- Fuel supply pipe
- 6- Clip for injector
- 7- 10 Nm

24-1

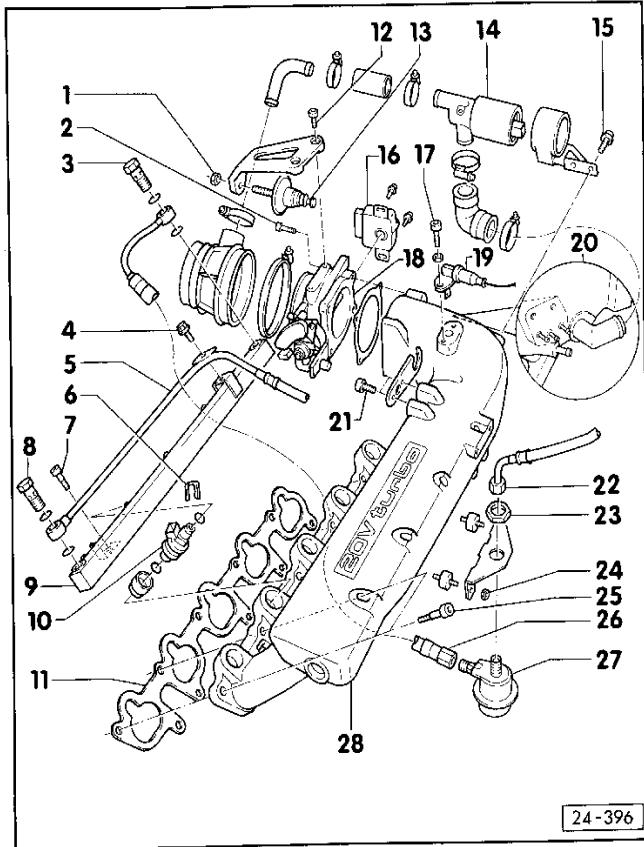

- 8- Banjo bolt 25 Nm
- 9- Fuel manifold
- 10- Injector
  - Renew lower and upper injector cap O-rings when disassembling
- 11- Gasket
- 12- 10 Nm
- 13- Throttle damper
  - Checking and adjusting - Repair Group 20
- 14- Idle stabilization valve -N7I
  - Checking - page 24-33
- 15- 10 Nm
- 16- Throttle valve potentiometer -G69 (with integrated idle switch)
  - Checking - page 24-54.
- 17- 10 Nm
- 18- Throttle valve housing
- 19- Intake air temperature sensor -G42
  - Checking - page 28-18
- 20- Vacuum connections
  - Page - 24-67

24-2

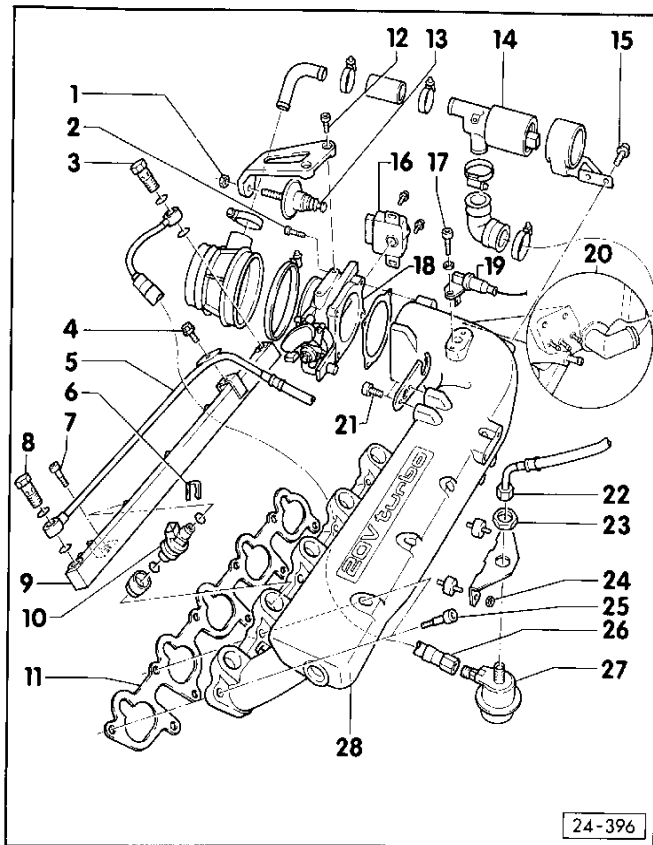

- 21- 20 Nm
- 22- Fuel return line (25 Nm)
- 23- 20 Nm
- 24- 10 Nm
- 25- 25 Nm
- 26- 20 Nm
- 27- Pressure regulator
- 28- Intake manifold

24-3

TECHNICAL DATA

System pressure (in bar) with engine running:	
without vacuum:	3.0 ... 3.2
with vacuum:	2.4 ... 2.7
Holding pressure 10 minutes (minimum pressure in bar)	
cold engine:	2.5
warm engine:	2.8
Injectors	
Injection quantities ml/30 sec. 150 - 170	
Idle Check*	
Engine rpm	800 ± 30
CO content vol. %	0.7 ± 0.20

\* Observe test requirements - page 24-31

24-4

#### RULES FOR CLEANLINESS

**Important!**

When working on the fuel supply/injection system observe the following "5 rules" for cleanliness.

- 1- Thoroughly clean all unions and the adjacent areas before disconnecting.
- 2- Place parts that have been removed on a clean surface and cover. Use paper or plastic sheet. Do not use fluffy cloths.
- 3- Components that have been opened or dismantled must be carefully covered or sealed if they repair can not to be carried out immediately.
- 4- Only install clean components.
  - Only unpack replacement parts immediately prior to installation.
  - Do not use parts that have been stored loose (for instance in tool boxes, etc.).
- 5- When the fuel system is open:
  - Do not work with compressed air if this can be avoided.
  - Do not move the car unless absolutely necessary.

24-5

#### SAFETY MEASURES

To prevent personal injury and/or destruction Motronic control unit it is important that the following be observed when working on vehicles equipped with the Motronic system:

**Important!**

- Before disconnecting battery earth strap recall code on radio units equipped with anti-theft code.
- Connect and disconnect the battery with the ignition switched off only, as the Motronic control unit can otherwise be damaged.
- Wait at least 20 sec. after switching off ignition before removing plug from Motronic control unit as the Motronic control unit could otherwise be damaged.

- Do not touch or disconnect ignition wires with engine running or at starter speed.
- Always ensure that ignition is switched off before disconnecting ignition wiring.
- Always ensure that ignition is switched off before disconnecting test equipment (rpm - ignition test).
- Neither an interference capacitor nor a test lamp is to be connected to Terminal 1 of the ignition coil.

24-6

- If the engine is to be turned over at starter speed (e.g., compression test, Motronic testing), the 3-pin plug from the ignition coil power output and the plugs for all 5 injectors are to be removed.
- The ignition coil is not to be replaced by a conventional coil.
- Do not disconnect battery with engine running.
- Do not attempt to simulate output signals by applying voltage to control unit.
- Do not activate starter with injectors removed.

24-7

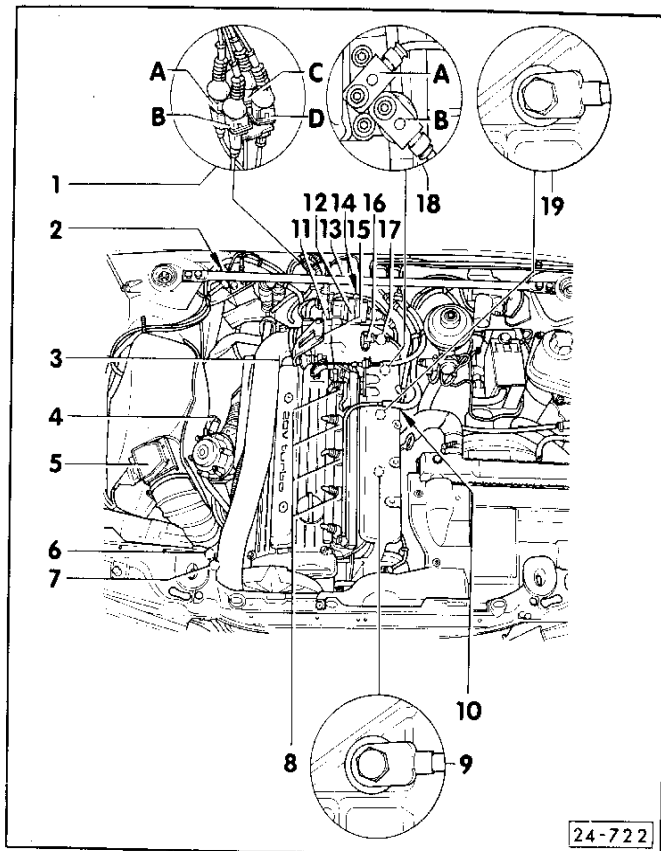

MOTRONIC COMPONENTS

- 1- Connection for
  - A - Front knock sensor I -G61  
(brown connector)
  - B - Rear knock sensor II -G66  
(green connector)
  - C - Firing point sensor -G4  
(reference point sensor, black connector)
  - D - Engine rpm sensor -G28  
(gray connector)
- 2- Connections for Lambda probe
  - Lambda probe heating -Z19  
(black 2-pin connector)
  - Lambda probe -G39  
(signal wire)
- 3- Coolant temperature sender -G62  
(on cylinder head, right rear)  
• Checking - page 28-20
- 4- lambda probe -G39  
• Checking - page 24-38
- 5- Air volume meter -G19  
• Checking - page 24-60
- 6- Solenoid valve for boost pressure limitation -N75  
• Checking - page 24-46

24-8

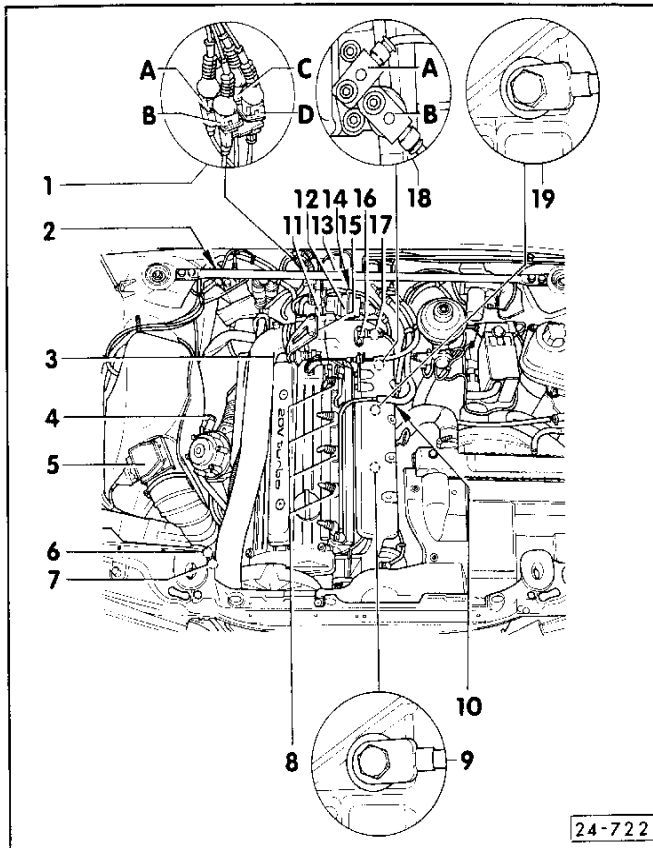

- 7- Overrun cut-off valve  
• Checking - Repair Group 21
- 8- Injectors  
• Checking - page 24-33
- 9- Front knock sensor I -G61
- 10- Fuel pressure regulator  
• Checking system and holding pressure  
- page 24-11
- 11- Throttle valve potentiometer -G69  
(with idle switch installed)
- 12- Idle stabilization valve -N71  
• Checking - page 24-33
- 13- Ignition coil -M  
• Checking - page 28-11
- 14- Solenoid for activated charcoal  
cannister  
-N80  
• Checking - page 24-42
- 15- Throttle valve housing
- 16- Sensor for intake air temperature -G42  
• Checking - page 28-18
- 17- Distributor -O with Hall sender -GH40  
• Checking Hall sender - page 28-25  
• Basic setting for Hall sender - page  
28-27

24-9

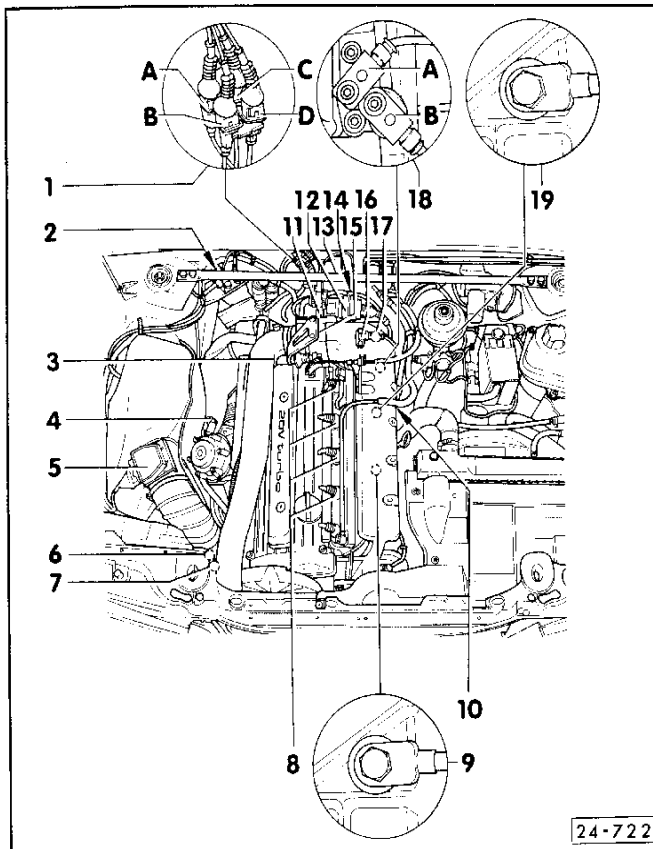

- 18- A Firing point sensor -G4  
(reference point sensor, black  
connector)  
• Checking - page 28-13
- B Engine rpm sensor -G28  
(gray connector)  
• Checking - page 28-15
- 19- Rear knock sensor II -G66

24-10

CHECKING SYSTEM AND HOLDING PRESSURES

Test conditions:

- Intact fuse (No. 13) in relay plate with fuse holder
- Fuel filter OK
- Battery fully charged (min. 12 V)

Checking system pressure

- Remove fuel pump relay from relay holder (relay position 10).
- ◀ - Connect V.A.G 1348/3A remote control with V.A.G 1348/3-2 adapter lead to Contact 52 and to positive terminal of battery.

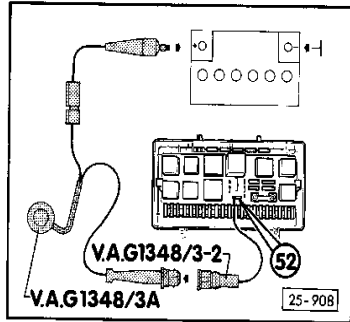

24-11

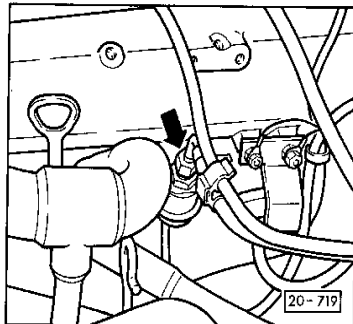

- ◀ - Unscrew fuel return line from pressure regulator.

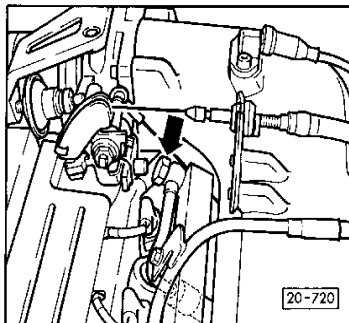

- ◀ - Unscrew connecting pipe between fuel manifold and pressure regulator from fuel manifold.

24-12

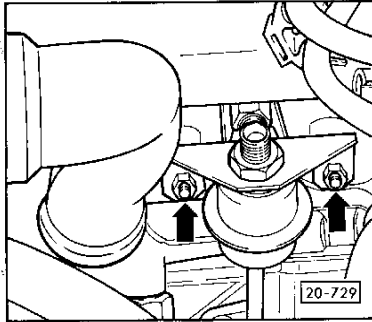

- ◀ - Unscrew pressure regulator with holder from intake manifold, loosen screw clamp and pull vacuum line from pressure regulator.
- Plug vacuum line.
- Carefully pull pressure regulator complete with connecting pipe through manifold.

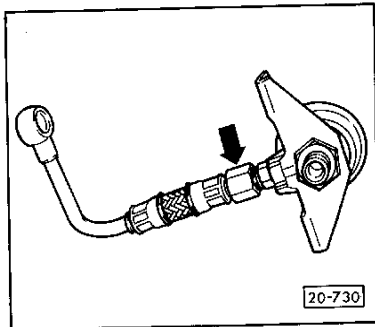

- ◀ - Unscrew connecting pipe from pressure regulator.

24-13

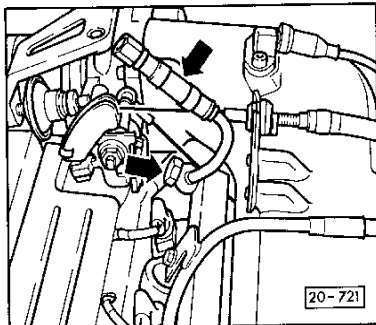

- ◀ - Turn connecting pipe 180° and attach connecting pipe to manifold.

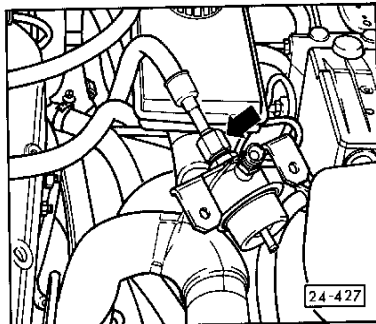

- ◀ - Connect fuel return pipe to pressure regulator.

24-14



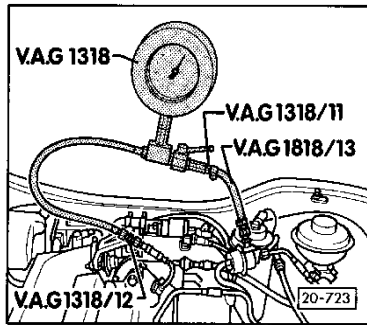

- ◀ - Connecting V.A.G 1318 pressure gauge between pipe and pressure regulator. Set pressure gauge lever to open position.

Note:

If fuel emerges from the pressure regulator vacuum connection during subsequent pressure testing, renew pressure regulator.

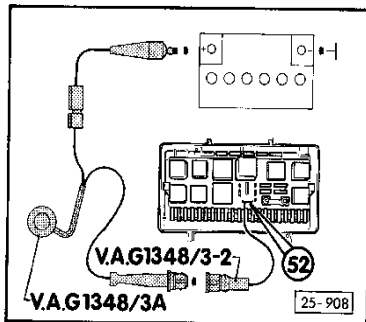

- ◀ - Briefly activate remote control - fuel pump should run.

- If fuel pump fails to run, check fuel pump, see Repair Group 20.

- Operate remote control until there is no further pressure increase.

- Specifications:

- 3.0 ... 3.2 bar with pump running

- 2.5 ... 2.7 bar immediately after switching off fuel pump

24-15

Note:

If no fuel pressure is built up, check whether fuel supply and return lines are reversed.

- If the specified pressure is not achieved, check fuel pump (Repair Group 20) and fuel supply line for leaks and/or damage (e.g., crushed areas near floor pan), replace as necessary.

- If specified pressure is still not reached, replace pressure regulator and repeat pressure test.

- If the specified pressure is exceeded, check return pipe for damage (e.g., crushed areas near floor pan) and flow, renew if necessary.

Important!

Excessive fuel pressure can rupture the pressure regulator diaphragm. This causes fuel to flow into the engine via the vacuum pipe (risk of petrol blow back).

- Remove remote control and reinstall fuel pump relay.

24-16

Note:

During the following test the engine should not be run for any longer than necessary with the vacuum hose disconnected, as the increase in fuel pressure results in fuel mixture enrichment which may in turn cause the Lambda control limits to be exceeded and a malfunction to be registered in the fault memory.

- Allow engine to idle.
- Switch off electrical consumers (air conditioner, etc.)
- Connect vacuum hose to regulator and observe pressure drop on gauge.
- When the hose is connected to the pressure regulator, the fuel pressure should drop by 0.5 bar approx.
- If this pressure change is not registered, perform the following checks:
  - Check vacuum hose for leaks (cracks, damage).
  - Check vacuum connection at intake manifold for free flow by disconnecting the hose from the pressure regulator and blowing through it.
- If the hose does not leak and the vacuum connector is not blocked, renew pressure regulator.
- For pressure regulator installation the removal sequence is reversed.
- - The connecting pipe should be secured to the pressure regulator in such a way that it aligns with the bracket.

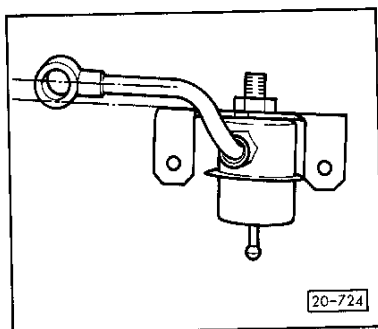

24-17

Checking holding pressure

- Holding pressure 10 minutes after engine is switched off (minimum pressure)
  - cold engine: 2.5 bar
  - warm engine: 2.8 bar

Note:

An increase in pressure due to fuel expansion is normal with warm engines.

- If the holding pressure is not achieved, perform the following checks:
  - Check the pressure gauge connections for leaks.
  - Check fuel pipes for leaks.
  - Check non-return valve in the electric fuel pump (see Repair Group 20).
  - Check injectors for leaks (page 24-23).
- If there are no leaks present and if the non-return valve in the electric fuel pump is OK, renew pressure regulator and repeat holding pressure check.
- After testing system and holding pressure, perform fault memory recall and cancel - Repair Group 01.

24-18

## CHECKING FUEL PUMP RELAY AND CONTROL SIGNAL

### Checking fuel pump relay -J17

- Remove fuses No. 13, 24, 26 and 28.  
Connect V.A.G 1527 diode test lamp between earth and rear contact for Fuse 13.
- Briefly operate starter.
- Specification: Fuel pump relay must pull in, diode test lamp must illumine.
- If the fuel pump relay does not pull in (can be felt and heard), check control signal - page 24-21.
- If the diode test lamp does not light up, check wiring connection - page 24-20.
- Connect diode test lamp to earth and then to left-side contacts of Fuses 24, 26 and 28 consecutively.
- Briefly operate starter.
- Specification: Diode test lamp must light up.
- If the diode test lamp fails to light up or lights up as soon as ignition is switched on, repeat test by connecting diode test lamp to the right-side contacts of the respective fuses.

24-19

- Specification: Diode test lamp must light up.
- If the diode test lamp still does not light up, check wiring connection, see below.
- If the diode test lamp lights up, reinstall Fuses 13, 24, 26 and 28.

### B - Checking wiring connections

- Ignition off
- Remove fuel pump relay -J17 from relay plate position 10.
- Use V.A.G 1526 digital multimeter to check for continuity at wiring connections between Fuse 13 and Contact 52, Fuse 26 and Contact 52, Fuse 24 and Contact 59 and between Fuse 28 and Contact 59 of relay position 10.
- Specification: Max. 0.5 ohm
- If the specified resistance is not achieved, use CFD to remedy open circuit.
- If no open circuit is found, check control signal for fuel pump relay - see next page.
- If the control signal is OK, renew fuel pump relay.

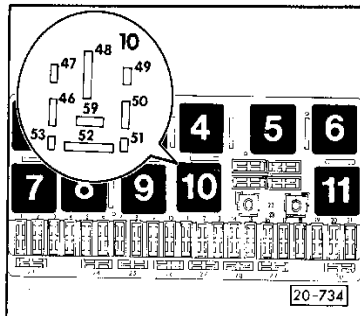

24-20

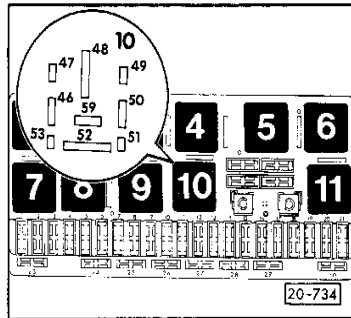

C - Checking fuel pump relay signal

- ◀ - Remove fuel pump relay -J17 from relay plate position 10.
- Switch on ignition.
- ◀ - Connect hand multimeter V.A.G 1526 between contacts 46 and 50 and between 48 and 50 on relay plate one after the other.
- Specification: approx. 12 V.
- If the specified values are not obtained use CFD to eliminate open circuit.
- Connect V.A.G 1527 diode test lamp to contacts 46 and 47.
- The test lamp should glow dimly when the ignition is switched on and become visibly brighter as soon as the starter is operated.
- If the diode test lamp glows dimly when the ignition is switched on without becoming brighter when the starter is operated, replace Motronic control unit.
- If the diode test lamp does not light up, check the wiring in the following manner:  
Connect V.A.G 1598 test box with 1598/5 adapter wire to wiring harness only of Motronic control unit, see page 01-57.

24-21

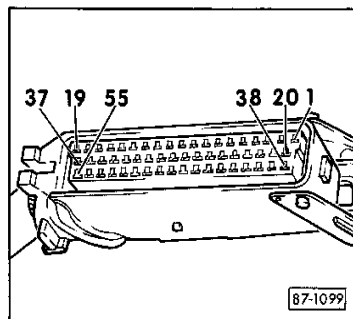

- ◀ - Check continuity between Contact 47 at relay position 10 and test box socket 3.
- Specification: Max. 1.0 ohm.
- If the specified resistance is not achieved, use CFD to remedy open circuit between Contact 47 on relay base and Contact 3 of control unit plug.
- If there is no open circuit and the diode test lamp does not light up, replace control unit.
- Reinstall fuses No. 13, 24, 26 and 28.

24-22

### CHECKING INJECTORS

- Perform final control element diagnosis - Repair Group 01.
- If all injectors fail to click, check control system to signal injectors (page 24-24).
- If one or several injectors do not click, begin by performing electrical check of injectors - see below.  
If the injectors are OK electrically, connect substitute injector for test purposes and repeat final control element diagnosis. If this injector clicks, renew defective injector.

#### Note:

Only a genuine injector designed for 5 cylinder Motronic may be used for this test.

- If the injectors do not click although they are in order check control signal to injectors (page 24-24).

#### Electrical check of injectors

- Remove plug from injector to be tested.
- Connect V.A.G 1526 hand multimeter to injector being tested.
- Specifications: 15 ... 17 ohms.
- If the specified resistance is not achieved, renew the injector.

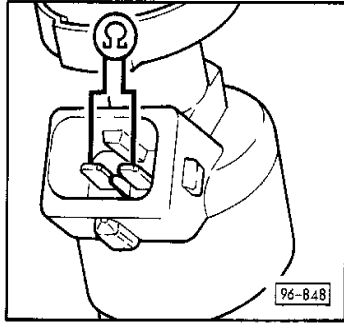

24-23

#### Checking control signal to injectors

- Remove plug from injector to be tested.
- Remove Fuse 28, check Fuse 27.
- Connect V.A.G 1527 diode test lamp to Contact 2 of plug and to engine earth.
- Switch on ignition, diode test lamp must light up.
- If the diode test lamp does not light up, connect V.A.G 1598 test box with adapter wire 1598/5 to Motronic control unit (see Repair Group 01).

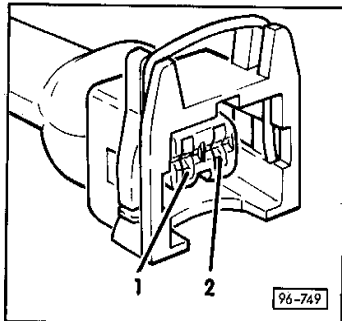

- Connect V.A.G 1527 diode test lamp to earth (socket 19) and socket 37 of test box.
- Switch on ignition, diode test lamp must light up.
- If the diode test lamp now lights up use CFD to locate and remedy the open circuit between Contact 37 of plug on Motronic control unit and Contact 2 of plug on injector.
- If the diode test lamp does not light up, renew Motronic control unit.

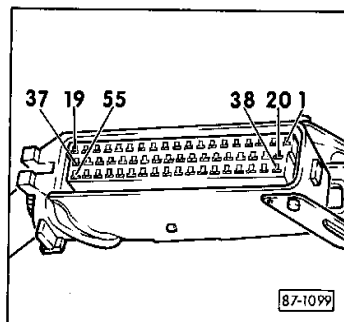

24-24

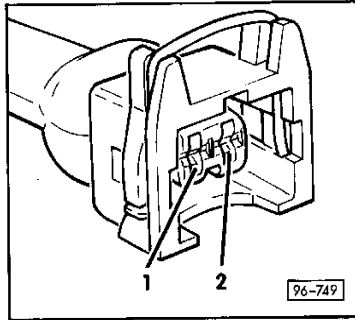

- Insert Fuse 28.
- ◀ - Connect V.A.G 1527 diode test lamp to Contact 2 of plug on injector and to engine earth.

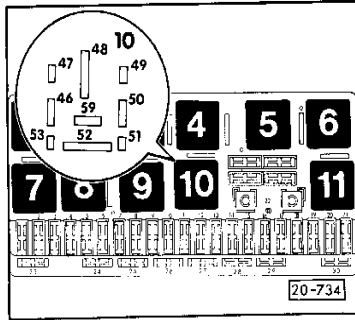

- Switch on ignition and operate starter for several seconds.
- Diode test lamp should light up when ignition is switched on and during starting procedure.
- If the diode test lamp goes out when starter is actuated, perform the following checks:
  - Check Fuse 28.
  - Consult CFD to check continuity between Contact 2 of plug on injector and Fuse 28 with ohmmeter.
- ◀ • Use CFD to check continuity in circuit from Fuse 28 to fuel pump relay -J17 (relay position 10) Contact 59.
- Check fuel pump relay and, if necessary, control signal to fuel pump relay - page 24-19.

24-25

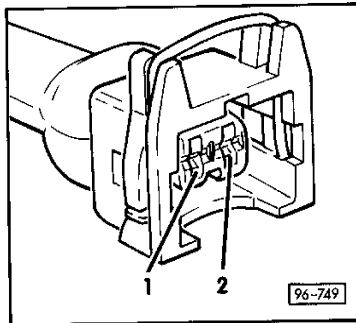

- ◀ - Connect V.A.G 1527 diode test lamp to Contact 1 and 2 of plug of injector being tested.
- Initiate final control element diagnosis (see Repair Group 01). When the injector being tested is activated, the diode test lamp must flash briefly (max. 5 times).
- If diode test lamp does not flash or remains lit, connect V.A.G 1598 test box with V.A.G 1598/5 adapter to wiring harness of Motronic control unit, see Repair Group 01. (The plug on control unit is not to be connected).
- Consult CFD to check the following wires for continuity or short to earth using an ohmmeter:

Injector Cylinder	Between contacts on injector	and test box socket
1	1	17
2	1	16
3	1	15
4	1	35
5	1	34

24-26

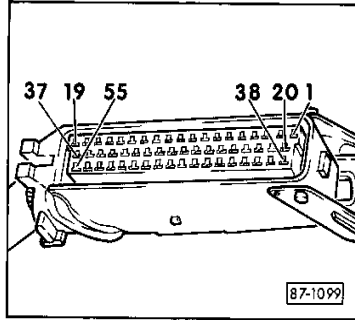

- \* - If necessary, eliminate open circuit between Motronic control unit plug in question and Contact 1 of injector connector.
- Eliminate short circuit to earth.
- If no open circuit or short circuit to earth is present, renew Motronic control unit.

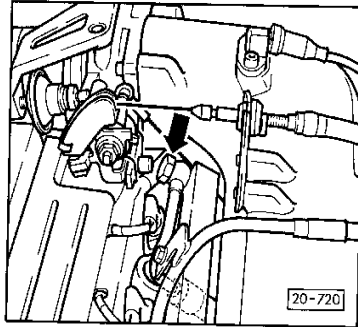

Checking injectors for injection quantity and for leaks

Test conditions:

- System pressure OK
- \* - Unscrew connecting pipe from fuel manifold to pressure regulator at fuel manifold.
- Unscrew fuel return line at pressure regulator.

24-27

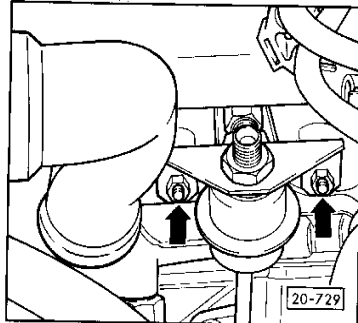

- \* - Unscrew pressure regulator with bracket from intake manifold and carefully pull connecting line through intake manifold.
- Reconnect fuel return pipe to pressure regulator.
- Remove plugs from injectors.
- Remove fuel manifold and take out complete with injectors.

Note:

When reinstalling, ensure that the injector O-rings are not damaged. Renew O-rings and coat lightly with clean engine oil.

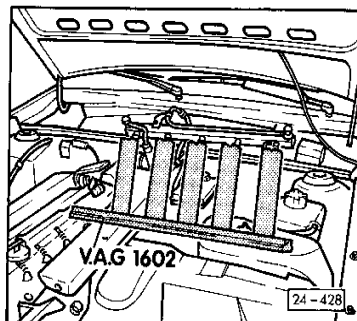

- \* - Attach connecting line to fuel manifold and place injectors in V.A.G 1602 injection quantity test unit.

24-28

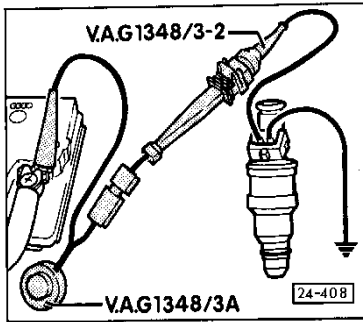

- Connect one contact of each injector being tested to engine earth with test leads and alligator clip from V.A.G 1594.
- Connect second contact of injector to positive using V.A.G 1348/3 A remote control, V.A.G 1348/3-2 adapter lead and jumper wire.

- Use adapter wire 1598/5 to connect V.A.G 1598 test box to Motronic control unit, see Repair Group 01.
- Switch on ignition.
- Connect Socket 3 and Socket 10 to the test box using measuring wire and "flying" fuse (8 A). (This activates the electric fuel pump).
- Check injectors for leaks (visual inspection). Only 1 to 2 drops per minute should escape from each injector when the fuel pump is operating.
- If fuel loss is greater:
- Switch off ignition and renew leaking injector.

24-29

- Switch on ignition.
- Operate V.A.G 1348/3 A remote control for 30 seconds.
- Having activated all 5 injectors, switch off ignition and place injection quantity measuring unit V.A.G 1602 on a flat surface.

Specification: 150 ... 170 ml

If the fuel quantity measured is below or above the specified amount:

- Renew faulty injector.

Note:

The upper and lower O-rings are always to be replaced after injector removal.

24-30



## CHECKING IDLE SPEED AND CO CONTENT

### Checking idle speed

#### Note:

Idle speed can not be adjusted.

#### Test conditions:

- Recall fault memory (Repair Group 01)
- Engine warm, oil temperature at least 80°C
- Throttle valve at idle position
- All electrical consumers off
- Air conditioner switched off
- Pressure gauge not connected

#### Importance!

The electric fan for the radiator should not be running when the test is being performed

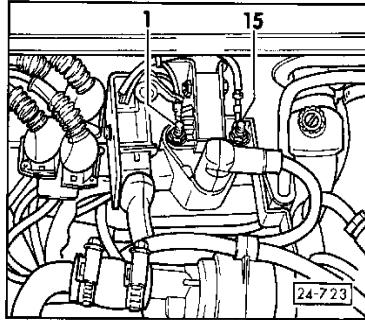

- Connect V.A.G 1367 test unit:
  - Negative terminal to engine earth
  - Positive terminal (red terminal) to Terminal 15 of ignition coil
  - Measuring wire (green terminal) to Terminal 1 of ignition coil
  - Select cylinder speed 5
- Allow engine to idle.
- Specification: 770 ... 830 rpm.
- If the specified engine speed is not obtained the following tests should be performed as described in Repair Group 01:
  - Repeat fault memory recall
  - Perform final control element diagnosis
  - Check basic setting

24-31

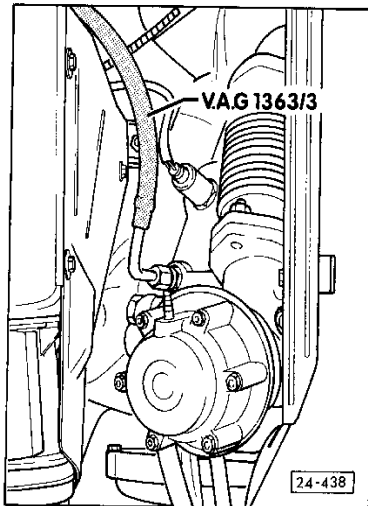

### Checking CO content

#### Note:

The CO content can not be adjusted.

#### Test conditions:

- Engine warm, oil temperature at least 80°C
  - Throttle valve in idle position
  - All electrical consumers off
  - Air conditioning switched off
  - Pressure gauge not connected
  - Crankcase breather connected
  - Perform fault memory recall (Repair Group 01)
- Consult operating instructions to connect V.A.G 1363 CO tester to CO tap next to Lambda probe with hose adapter V.A.G 1363/3.
  - Allow engine to idle.
  - Specification: 0.5 ... 0.9 % vol.
  - If the reading is not obtained check whether all spark plugs are functioning properly.
- #### Note:
- A defective spark plug will result in a considerable increase in CO content.
- If the specified figure is not obtained the following checks should be performed as described in Repair Group 01:
    - Repeat fault memory recall
    - Perform final control element diagnosis
    - Check basic settings

24-32

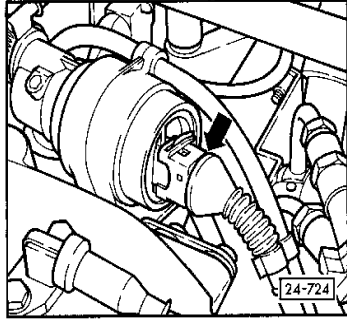

#### CHECKING IDLE SPEED STABILIZATION

##### Electrical check of valve for idle speed stabilization -N71

- ◀ - Remove connector from idle speed stabilization valve.

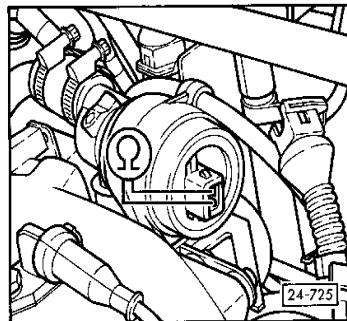

- ◀ - Connect V.A.G 1526 hand multimeter with jumper lead from V.A.G 1594 to measure resistance at idle speed stabilization valve.  
Specification: 7 ... 11 ohms
- If the specified resistance is not achieved, renew injector.

##### Note:

At room temperature resistance is at the lower, and at engine temperature at the higher end of the tolerance range.

24-33

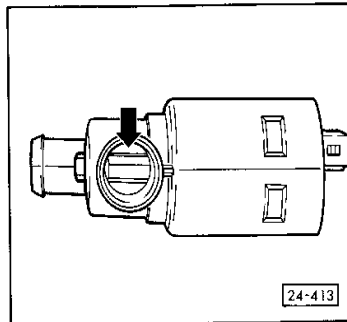

##### Mechanical check of idle stabilization valve

- Remove idle stabilization valve.
- ◀ - Check rotary slide valve for signs of wear (visual inspection).

##### Important!

When checking for free movement, do not use screwdriver or other tool to move rotary slide valve.

- Connect plug to idle stabilization valve.
- Initiate final control element diagnosis (Repair Group 01) and send control signal to idle stabilization valve.
- Check whether rotary slide valve runs from stop to stop properly.
- If there are signs of scoring which impair free movement or if the rotary slide valve does not move smoothly (hangs up, runs slowly or does not run to stop), renew valve.

##### Checking control signal to idle stabilization valve

- Detach connector plug from idle stabilization valve.

24-34

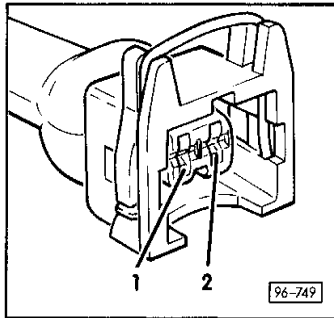

- ◄ - Connect V.A.G 1527 diode test lamp and test wire from V.A.G 1594 auxiliary test set to Contact 1 of plug and to engine earth.
- Operate starter for several seconds, diode test lamp must light up. If diode test lamp fails to light up, the following checks should be made:
  - Check Fuses 24 and 28.
  - Consult CFD to check continuity in circuit between Contact 1 of socket on idle stabilization valve and Fuse 24, specification: max. 0.5 ohm.

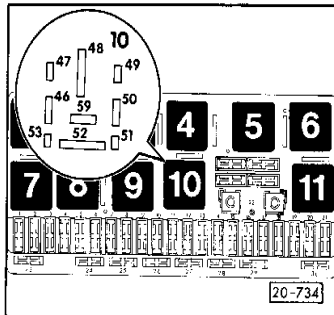

- ◄ • Consult CFD to check continuity between Fuse 24 and fuel pump relay -J17 (relay position 10) contact 59. Specification: max. 0.5 ohm.
- Check control signal to fuel pump relay - page 24-19.
- Connect diode test lamp once again as described above.
- Initiate final control element diagnosis (Repair Group 01).
- Diode test lamp must light up.

Note:

Positive current should always be on Contact 1 independently of which final control element is called up.

24-35

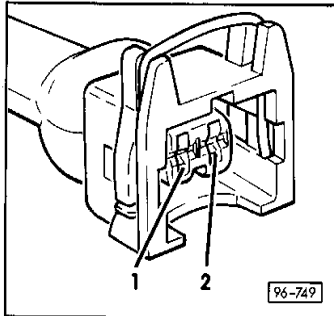

- If diode test lamp does not light up, connect V.A.G 1598 test box with 1598/5 adapter wire to wiring loom only of Motronic control unit, see Repair Group 01.
- ◄ - Consult CFD to make continuity check for wiring between Contact 1 of socket for idle speed stabilization valve and Socket 37 of the test box and ...

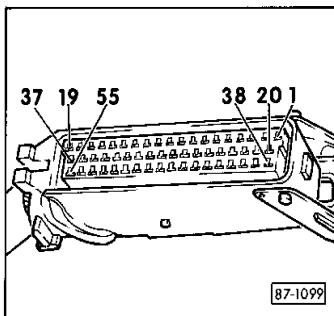

- ◄ - ... repair open circuit between Contact 37 of the connection on control unit and Contact 1 of socket on idle stabilization valve if necessary.
- If no open circuit is present, renew control unit.
- Remove V.A.G 1598 test box and V.A.G 1598/5 adapter cable.
- Connect Motronic control unit to vehicle wiring loom.

24-36

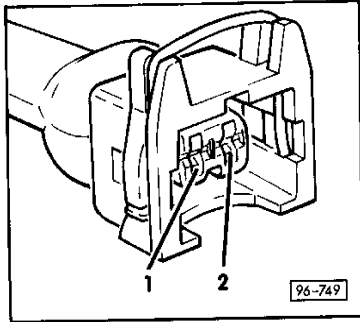

◀ - Connect V.A.G 1527 diode test lamp with measurement wire to Contact 1 and 2 of connector on idle stabilization valve.

- Initiate final control element diagnosis (Repair Group 01). Diode test lamp should flash when idle speed stabilization valve is activated (lamp varies slightly in brightness but does not go out).

- If diode test lamp does not flash or if it lights up constantly, connect V.A.G 1598 test box with V.A.G 1598/5 adapter wire to wiring loom of Motronic control unit only, see Repair Group 01.

- If diode test lamp remains lit constantly, check wiring between Contact 2 of connector from idle stabilization valve and Socket 4 of the test box for short to earth.

- If diode test lamp does not flash, check circuit continuity between Contact 2 of connection on idle stabilization valve and Socket 4 of test box.

◀ - Where required, repair short to earth/open circuit between Contact 2 of connector on idle stabilization valve and Contact 4 on plug of Motronic control unit.

- If no open/short circuit is present, renew control unit.

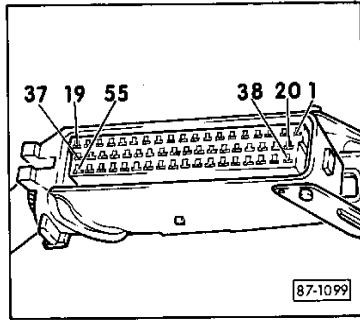

24-37

#### CHECKING LAMBDA PROBE -G39 AND LAMBDA CONTROL

##### Checking lambda probe heater -Z19

The plug connector for the Lambda probe heater is located at the right rear of the engine compartment - see also page 24-8, position 2.

◀ - Unplug connector (2).

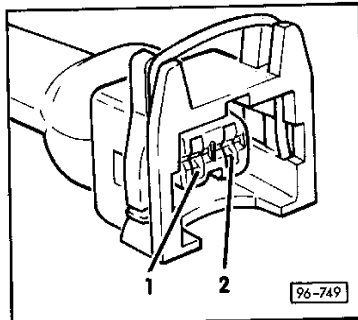
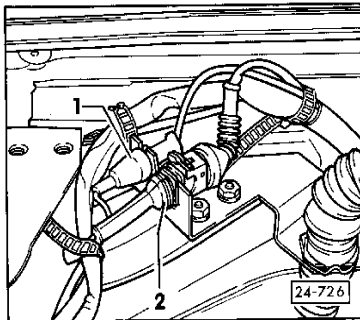

◀ - Switch V.A.G 1526 hand multimeter with adapter lead from V.A.G 1594 to voltage measurement between Contacts 1 and 2 of connector.

- Run engine.

- Specification: Approx. 12 - 14 volts.

- If specified voltage is not achieved, the following checks, indicated by the dots, should be carried out:

- Check Fuse 26.
- Consult CFD to check continuity between Contact 2 and Fuse 26. Specification: Max. 0.5 ohms (check terminal assignments where necessary).
- Make continuity check between Contact 1 and engine earth, Specification: Max. 0.5 ohms.

24-38

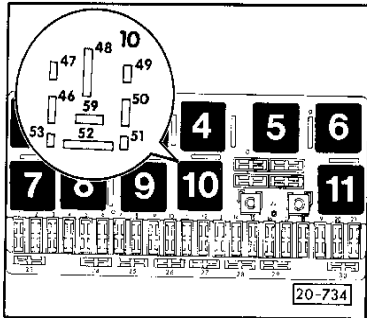

- Consult CFD to check continuity between Fuse 26 and Contact 52 of fuel pump relay - J17 (relay position 10). Specification: Max. 0.5 ohms.

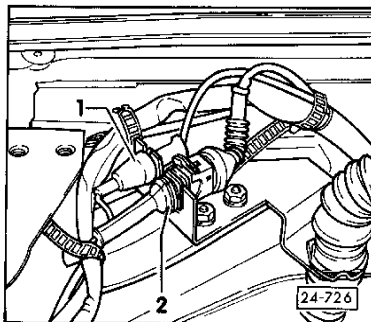

- If circuit is not open, place V.A.G 1315 A/1 auxiliary measurement lead in connector (2) and connect to 10A input of V.A.G hand multimeter.
- Let engine run.
- Specification: 0.5 - 3.0 A. (Current decreases as probe becomes warmer).
- If specification is not achieved, replace Lambda probe.

24-39

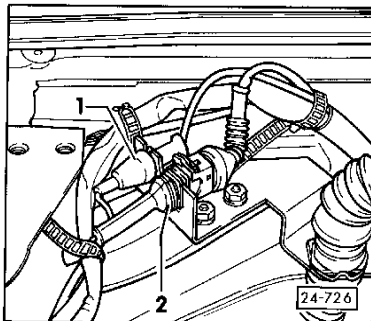

Checking control signal to lambda probe (-639)

- Separate plug connector (1) (Lambda signal wire).
- Connect V.A.G 1526 with adapter wire from V.A.G 1594 to measure voltage between plug connector of Motronic control unit and engine earth.
- Switch on ignition.
- Specification:  $450 \pm 50$  mV.
- If specification is not achieved, connect V.A.G 1598 test box with adapter wire 1598/5 to wiring loom of Motronic control unit only, see Repair Group 01.

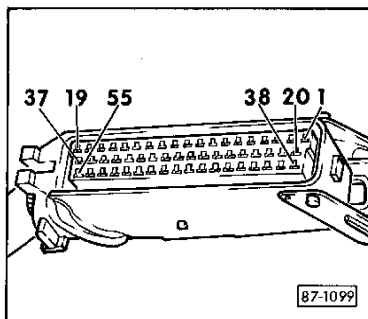

- Consult CFD to check continuity between connector in engine compartment and Socket 28 of the test box. Specification: 1.0 ohms. Where indicated, repair open circuit between plug in engine compartment and Contact 28 of plug in control unit.
- Use CFD to check resistance in earth connection between engine block and Socket 10 of test box with ohmmeter. Specification: Max. 1.0 ohm. Repair open circuit where necessary.
- Check basic setting of engine before checking operation of Lambda control - see Repair Group 01. The value in display field 8 should not be a constant 128, but should fluctuate between 123 and 133.

24-40

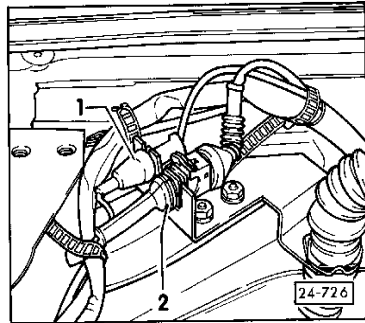

#### REMOVING AND INSTALLING LAMBDA PROBE -G39

The plug connections for the Lambda probe are located at the right rear of the engine compartment - see also page 24-8, position 2.

- ◀ - Separate both plug connections.
- Open cable ties.
- Unscrew Lambda probe (location and tightening torque - see Repair Group 26).

When installing the Lambda probe the following points should be observed:

- It is important that cable ties again be installed to prevent the probe cable from coming into contact with the exhaust pipe.
- The Lambda probe threads are coated with an installation paste. This paste must not get into the probe slots.

24-41

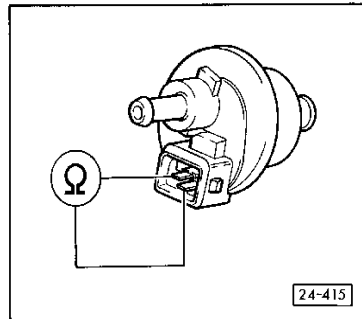

#### CHECKING ACTIVATED CHARCOAL FILTER SYSTEM SOLENOID VALVE I -N80

The solenoid valve for the activated charcoal filter is located behind the engine between cylinder head and bulkhead.

#### Electrical check of Solenoid Valve I for activated charcoal filter

- Remove plug from solenoid valve.
- ◀ - Measure resistance of solenoid valve with V.A.G 1526 hand multimeter and adapter wire from V.A.G 1594. Specification: 40 - 50 ohms.
- If specified resistance is not achieved, renew valve.

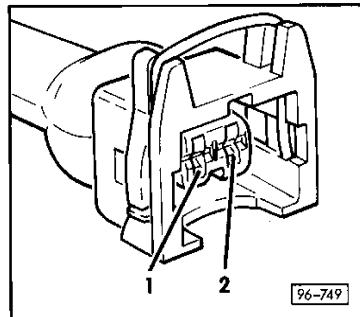

#### Checking solenoid valve control signal

- Pull plug from solenoid valve.
- ◀ - Connect V.A.G 1527 diode test lamp with test wire from V.A.G 1594 measurement aids set to Contact 2 of connector and to engine earth.
- Operate starter for several seconds; the diode test lamp must light up.
- If the diode test lamp does not light up, the following points, identified with dots, are to be performed:
  - Check Fuse 24 and 28.

24-42

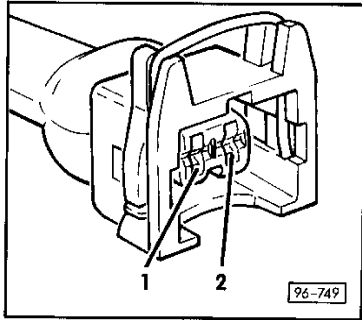

- Consult CFD to check continuity of wire from Contact 2 of plug on ACF valve to Fuse 24. Specification: Max. 0.5 ohms.

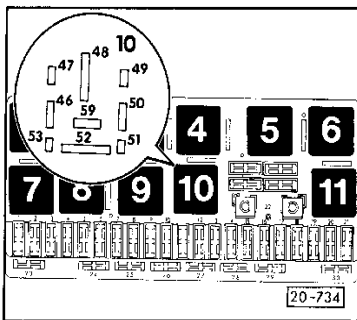

- Use CFD to check continuity of wire from Fuse 24 to Contact 59 of fuel pump relay - J17 (relay position 10). Specification: Max. 0.5 ohms.
  - Check control signal to fuel pump relay (page 24-19).
- Reconnect diode test lamp as described on page 24-42.
  - Initiate final control element diagnosis (Repair Group 01).
  - Diode test lamp must light up.

**Note:**

Positive current is always to be on Contact 2 of plug for solenoid valve irregardless of which final control element is called up.

24-43

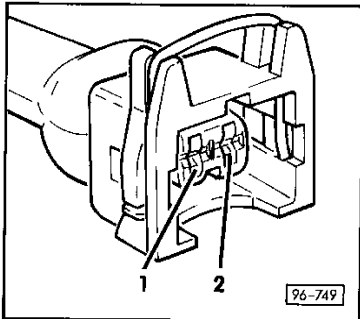

- If diode test lamp does not light up, connect V.A.G 1598 test box with adapter wire 1598/5 to wiring loom of Motronic control unit only, see Repair Group 01.
- Consult CFD to check continuity between Contact 2 of connector at solenoid valve and Socket 37 of test box. Specification: Max. 1.0 ohm.

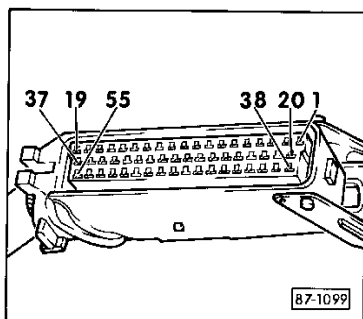

- Where necessary, eliminate open circuit between Contact 37 of plug at control unit and Contact 2 of plug at solenoid valve for activated charcoal filter.
- If no open circuit is present, renew control unit.
- Remove V.A.G 1598 test box and V.A.G 1598/5 adapter wire.
- Connect Motronic control unit to vehicle wiring loom.

24-44

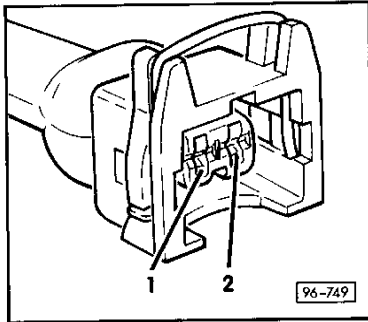

4 - Connect V.A.G 1527 diode test lamp with measuring wire to Contact 1 and 2 of connector on ACF valve.

- Initiate final control element diagnosis (Repair Group 01). When the ACF valve is activated, diode test lamp should flash.

- If the diode test lamp does not flash or remains lit continuously, connect V.A.G 1598 test box with V.A.G 1598/5 adapter wire to wiring loom of Motronic control unit only, see Repair Group 01.

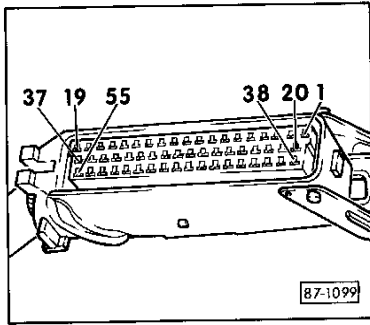

- If the diode test lamp remains lit constantly, check for short to earth in wire from Contact 1 of connector at ACF valve to Socket 5 of test box.

- If diode test lamp does not flash, check continuity in circuit between Contact 1 of connector at ACF valve and Socket 5 of test box. Specification: Max. 1.0 ohm.

4 - Where necessary, eliminate short/open circuit between Contact 1 of plug on solenoid valve and Contact 5 of plug on Motronic control unit.

- If there is no open circuit or short circuit to earth in the wire, renew control unit.

24-45

CHECKING BOOST PRESSURE LIMITING SOLENOID - N75

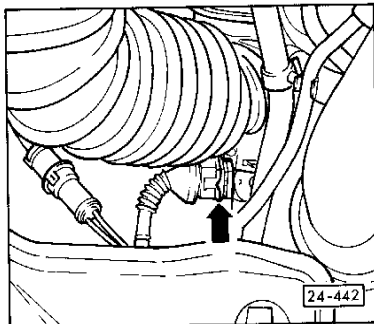

The solenoid valve for boost pressure limitation is located forward of the turbo charger.

The solenoid valve for boost pressure limitation regulates the control pressure for the wastegate, thus determining boost pressure.

If no current is present at the solenoid valve (e.g., plug removed), boost pressure is limited.

Electrical check of boost pressure limiting solenoid

4 - Remove plug from boost pressure limiting solenoid.

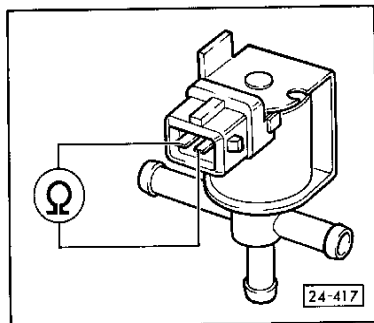

4 - Measure resistance by connecting V.A.G 1526 hand multimeter with adapter lead from V.A.G 1594 to solenoid valve for boost pressure limitation. Specification: 25 - 35 ohms.

- If specified value is not achieved, renew valve.

24-46



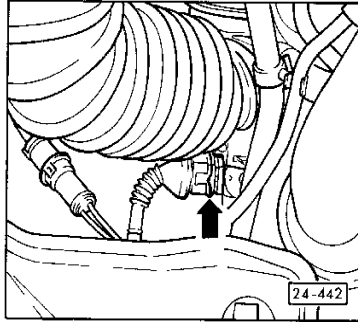

Testing boost pressure limiting solenoid control circuit

- ◀ - Pull connector plug from boost pressure limiting solenoid.

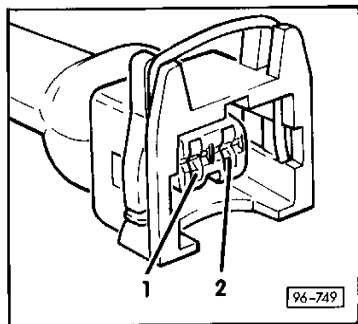

- ◀ - Connect V.A.G 1527 diode test lamp with test lead from V.A.G 1594 test aid set to Contact 1 of connector and to engine earth.
- Operate starter for several seconds, diode test lamp must light up.
- If the lamp does not light up the following checks, indicated by dots, are to be performed:
  - Check Fuses 24 and 28.

24-47

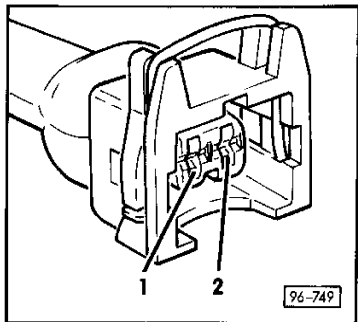

- Consult CFD to check continuity in circuit between Contact 1 of connector at solenoid valve for boost pressure limitation and Fuse 24. Specification: Max. 0.5 ohm.

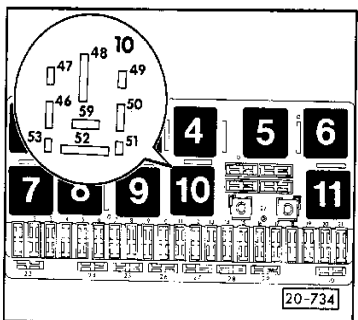

- Consult CFD to check continuity in circuit between Fuse 24 and fuel pump relay -J17 (relay position 10) Contact 59. Specification: Max. 0.5 ohm.
- Check fuel pump relay control signal (page 24-19).
- Connect diode test lamp once again as described on page 24-47.
- Initiate final control element diagnosis (Repair Group 01).
- Diode test lamp must light up.

**Note:**  
Positive current must be on Contact 1 of connector at solenoid valve for boost pressure limitation independent of which final control element is called up.

24-48

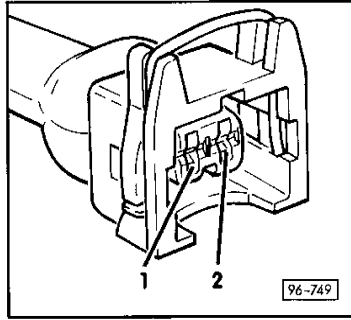

- If diode test lamp does not light up, connect V.A.G 1598 test box with adapter lead 1598/5 to wiring loom at Motronic control unit only, see Repair Group 01.
- ◀ - Consult CFD to check continuity in circuit between Contact 1 of connector at solenoid valve for boost pressure limitation and Socket 37 of test box. Specification: Max. 1.0 ohm.

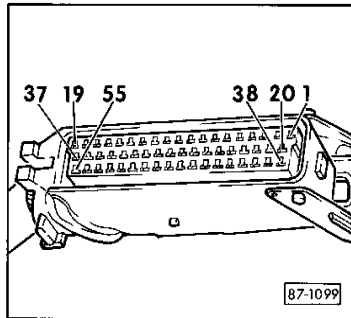

- ◀ - If necessary, rectify open circuit between Contact 37 of plug at control unit and Contact 1 of plug at solenoid valve for boost pressure limitation.
- If no circuit interruption is present, renew control unit.
- Remove V.A.G 1598 test box and V.A.G 1598/5 adapter.
- Connect Motronic control unit to the vehicle wiring loom.

24-49

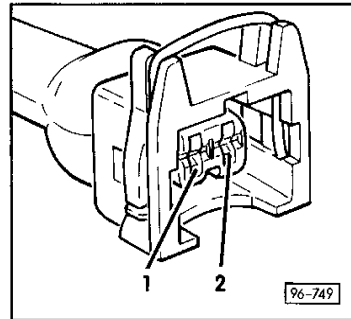

- ◀ - Connect V.A.G 1527 diode test lamp with measurement wire to Contact 1 and 2 of connector at solenoid valve for boost pressure limitation.
- Initiate final control element diagnosis (Repair Group 01). When signal is sent to solenoid valve for boost pressure limitation, diode test lamp must flash.
- If diode test lamp does not flash or if it lights continually, connect V.A.G 1598 test box with 1598/5 adapter to wiring loom at Motronic control unit only, see Repair Group 01.

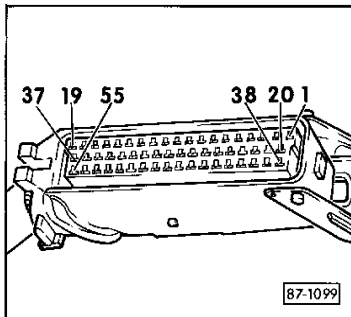

- If the diode test lamp stays lit constantly, check for short to earth in circuits between Contact 2 of connector at solenoid valve for boost pressure limitation and Socket 23 of test box.
- If diode test lamp does not flash, check for continuity in circuit between Contact 2 of connector at solenoid valve for boost pressure limitation and Socket 23 of test box. Specification: Max. 1.0 ohm.
- ◀ - If necessary, eliminate short/open circuit between Contact 2 of connector at solenoid valve for boost pressure limitation and Contact 23 of connector at Motronic control unit.
- If there is no earth short or open circuit, the control unit must be renewed.

24-50

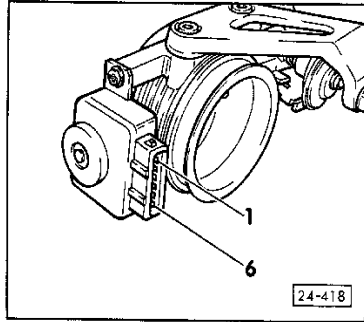

CHECKING AND ADJUSTING IDLE SPEED SWITCH

The idle speed switch is located inside the throttle valve potentiometer.

- Installation location of throttle valve potentiometer - see page 24-8.

Checking idle speed switch

- Disconnect plug from throttle valve potentiometer.
- ◀ - Measure resistance by connecting V.A.G 1526 hand multimeter with adapter from V.A.G 1594 to Contacts 4 and 6.

Specification: zero ohm (continuity).

- Rotate throttle valve slightly.

Specified resistance: Infinite ohm (no continuity).

If the reading is not obtained or is not obtained until the throttle valve has been opened much further, the idle speed switch must be adjusted.

- If the specified value is still not achieved after the idle speed switch is adjusted, renew throttle valve potentiometer.

24-51

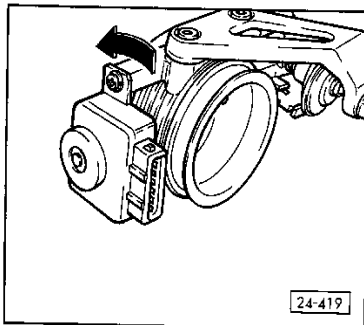

Adjusting idle speed switch

- Loosen both throttle valve potentiometer securing screws.
- ◀ - Rotate throttle valve potentiometer in direction of arrow until stop is felt. The throttle valve itself must not be rotated.
- Secure throttle valve potentiometer in this position.
- Recheck idle speed switch - see page 24-51.

Checking circuit between idle speed switch and Motronic control unit

- Connect V.A.G 1598 test box with V.A.G 1598/5 adapter to wiring loom of Motronic control unit only, see Repair Group 01.
- Remove plug from throttle valve potentiometer.

24-52

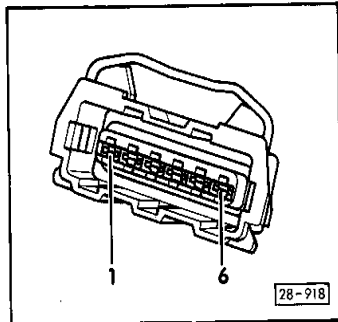

- ◀ - Consult CFD to check the following wires for continuity and short circuit:

Plug contact	V.A.G 1598 socket
4	10
6	52

Specification: Max. 1.0 ohm.

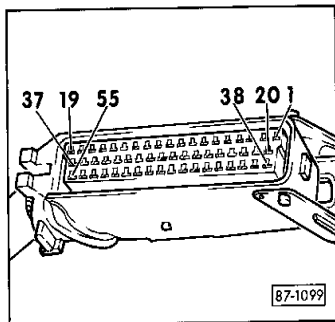

- ◀ - Where necessary, consult CFD to eliminate open/short circuit.

**Important!**  
Use only gold-plated contacts when servicing the throttle valve potentiometer plug.

24-53

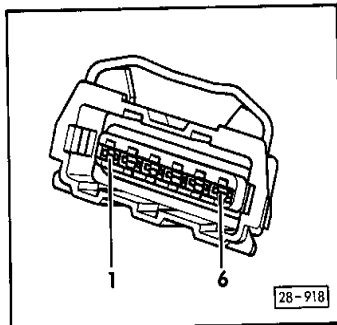

#### CHECKING AND ADJUSTING THROTTLE VALVE POTENTIOMETER -G69

- Installation location of throttle valve potentiometer - see page 24-9.

#### Checking voltage supply

- Remove plug from throttle valve potentiometer.
- Switch on ignition.
- ◀ - Measure voltage by switching V.A.G 1526 hand multimeter with auxiliary jumper from V.A.G 1594 consecutively between Contacts 1 and 2 as well as 1 and 3.
- Specification: 4.5 - 5.5 volts each.
- If specified voltages are achieved, check resistance of throttle valve potentiometer - page 24-56.
- If specification is not achieved, check wiring to Motronic control unit and Motronic control unit as follows:
- Switch off ignition.
- Connect V.A.G 1598 test box with V.A.G 1598/5 adapter to wiring loom of Motronic control unit only, see Repair Group 01.

24-54

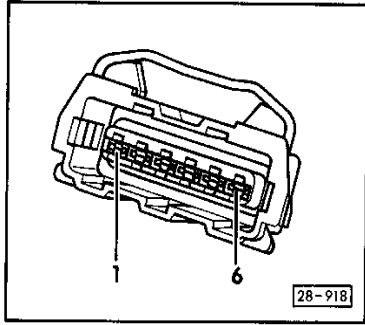

- ◀ - Consult CFD to check following circuitry for continuity and short circuit:

Plug contact	V.A.G 1598 socket
1	12
2	30
3	53

Specification: Max. 1.0 ohm.

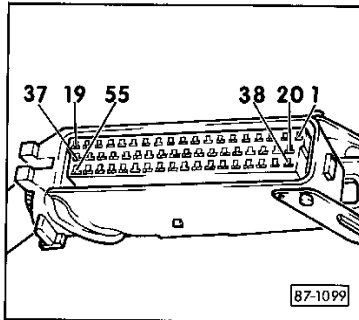

- ◀ - If necessary, consult CFD to eliminate open/short circuit.

**Important!**  
Use only gold-plated contacts when servicing the throttle valve potentiometer plugs.

24-55

- Connect V.A.G 1598-5 adapter at Motronic control unit.
- Switch on ignition.
- Switch V.A.G 1526 hand multimeter consecutively between Sockets 12 and 30 as well as 12 and 53.
- Specification: 4.5 - 5.5 volts each.
- If specification is not achieved, renew Motronic control unit.

Checking resistance of throttle valve potentiometer

- ◀ - Measure resistance by connecting V.A.G 1526 hand multimeter with V.A.G 1594 auxiliary jumper at Contact 1 and 2.

Specification: 1.5 - 2.6 kohm.

- Connect hand multimeter at Contact 2 and 3.

Specification at idle position:  
Approx. 0.75 - 1.3 kohm.

- Slowly move throttle valve lever to full load position (full throttle). The resistance should increase to a maximum of 3.6 kohm.

- If one of the specified readings is not obtained, renew throttle valve potentiometer.

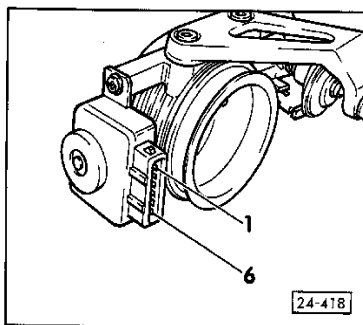

24-56

Adjusting throttle valve potentiometer

The adjustment of the idle switch automatically adjusts the throttle valve potentiometer.

Adjusting idle switch - page 24-51.

CHECKING ALTITUDE SENSOR

The altitude sensor is located in the passenger side footwell beneath the A-pillar trim.

Checking supply voltage

- Remove plug from altitude sensor.
- ◀ - Measure voltage by switching V.A.G 1526 hand multimeter with auxiliary jumper from V.A.G 1594 between Contacts 1 and 3, and 2 and 3 consecutively.

Specification: 4.5 - 5.5 volts each.

- If specified readings are not obtained, renew altitude sensor.
- If one of the specified readings is not obtained, check wiring to Motronic control unit and control unit itself in the following manner:

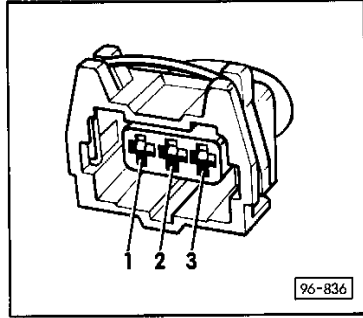

24-57

- Switch ignition off.
- Connect V.A.G 1598 test box with V.A.G 1598/5 adapter to wiring loom at Motronic control unit only, see Repair Group 01.

- ◀ - Consult CFD to check for continuity and short circuit in the following wiring:

Plug contact	V.A.G 1598 socket
1	46
2	12
3	30

Specification: Max. 1.0 ohm.

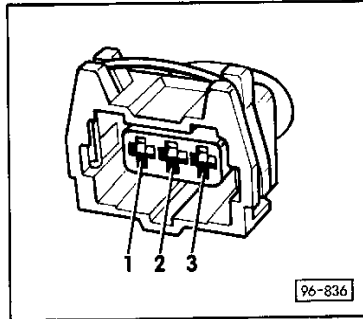

- ◀ - Where necessary, consult CFD to repair open/short circuit.

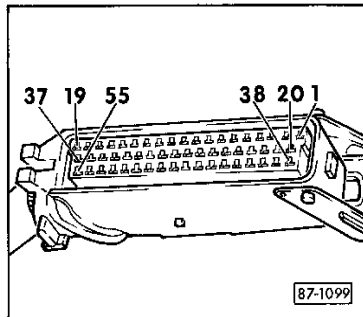

24-58

- Connect V.A.G 1598-5 adapter wire to Motronic control unit.
  - Switch on ignition.
  - Use V.A.G 1526 hand multimeter to measure between Sockets 12 and 30, and 46 and 30 consecutively.
- Specification: 4.5 - 5.5 volts each.
- If specified voltages are not achieved, renew Motronic control unit.

#### Checking altitude signal

- Connect V.A.G 1598 test box with V.A.G 1598/5 adapter to Motronic control unit, see Repair Group 01.
- Connect altitude sensor plug.
- Switch on ignition.
- Measure voltage between Sockets 30 and 46. The voltage must be between 0.5 and 4.0 V irregardless of altitude. Voltage decreases with increasing altitude. At altitudes below 2000 m the voltage must not be below 1.5 volts.
- If the voltage lies outside the tolerance range, renew altitude sensor.

24-59

#### CHECKING AIR VOLUME METER -G70

##### Important!

The hot wire in the air volume meter must not be touched.

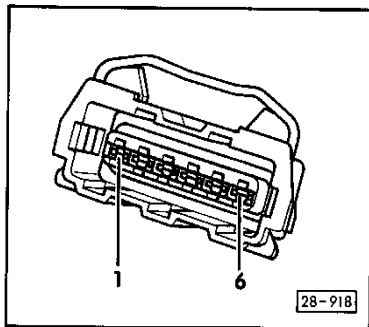

- Detach plug from air volume meter.
- Connect V.A.G 1527 diode test lamp between Contact 1 of the connector and positive battery terminal.
- Diode test lamp must light up.
- If diode test lamp does not light up, consult CFD to find and eliminate open circuit.
- Connect V.A.G 1527 diode test lamp between Contact 5 of connector at air volume meter and engine earth.
- Switch on ignition.
- Diode test lamp must light up.
- If diode test lamp fails to light up, connect V.A.G 1598 test box with V.A.G 1598/5 adapter wire to Motronic control unit, see Repair Group 01.

24-60

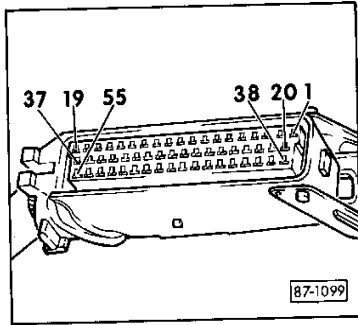

- Connect V.A.G 1527 diode test lamp to earth (Socket 19) and Socket 37 of test box.
- Switch on ignition, diode test lamp must light up.
- ◀ - If diode test lamp now lights up, consult CFD to find and eliminate open circuit between Contact 37 of connector at control unit and Contact 5 of connector at air volume meter.
- If diode test lamp fails to light up, renew control unit.

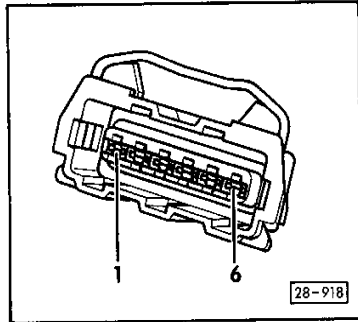

- ◀ - Connect diode test lamp at Contact 5 of connector at air volume meter and to engine earth.
- Switch on ignition and operate starter for several seconds.

24-61

- Diode test lamp must light up when ignition is switched on and during starting procedure.
- If diode test lamp goes out when starter is operated, the following checks should be performed:
  - Check Fuse 28.
  - Consult CFD to check continuity in wire between Contact 5 of connector at air volume meter and Fuse 28. Specification: Max. 0.5 ohm.
  - ◀ • Consult CFD to check continuity in wiring between Fuse 28 and fuel pump relay -J17 (relay position 10) Contact 59. Specification: Max. 0.5 ohm.
  - Check fuel pump relay and fuel pump relay control signal where necessary - page 24-19.

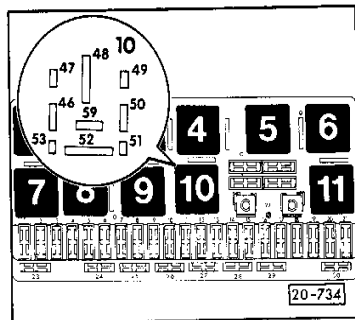

#### Checking signal wires

- Connect V.A.G 1598 test box with V.A.G 1598/5 adapter to wiring loom only of Motronic control unit, see Repair Group 01.
- Remove plug from air volume meter.

24-62



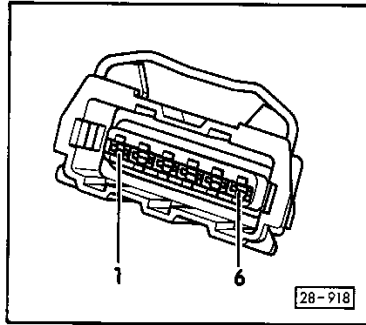

- ◀ - Check following wires for continuity or short circuit:

Contact in plug on air volume meter	To socket of test box
2	26
3	7
4	25

Specification: Max. 1.0 ohm.

- Eliminate open/short circuit where necessary.

**Important!**  
Use only gold-plated contacts when renewing air volume meter plug contacts.

#### Checking operation of air volume meter

- Remove plug from air volume meter.
- ◀ - Connect V.A.G 1526 hand multimeter with auxiliary wire from V.A.G 1594 to Contact 1 and 2 of air volume meter to measure resistance. Note resistance.
- Remove measuring wires at air volume meter and short them.

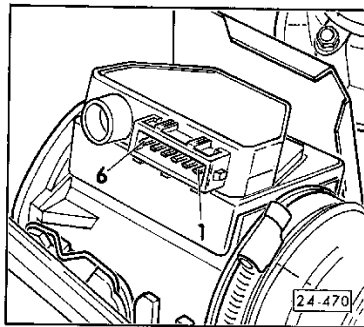

24-63

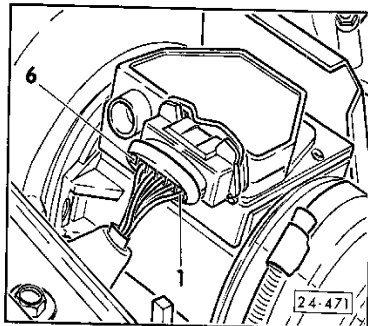

- The reading now displayed must coincide with that which has been previously noted. (The earth bridge in the air volume meter is measured.) The measured value corresponds to the internal resistance of the measurement wires.
- If the deviation in measurement figures is in excess of 0.1 ohm, renew air volume meter.
- ◀ - Connect plug to air volume meter and push back rubber grommet.
- Measure voltage by connecting V.A.G 1526 hand multimeter with auxiliary wire from V.A.G 1594 to Contact 1 and 3.
- Switch on ignition.  
Specification: Approx. 1.2 V - 1.5 V.
- Let engine idle.  
Specification: Approx. 2.5 volts.
- Briefly increase engine speed (accelerator).  
Specification: Unambiguous voltage increase to approx. 3 - 5 volts.
- If specified figures are not obtained, renew air volume meter.

#### Checking air volume meter burn-off:

The burn-off process occurs approximately 3 seconds after engine is switched off and lasts approx. 1 sec.

The burn-off process occurs only when the following conditions are met:

- Coolant temperature above 60°C
- Engine speed above 2000 rpm for 3 seconds
- Signal wires OK
- Fuse 28 OK

24-64

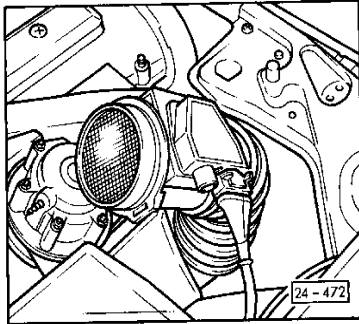

- ◀ - Unscrew air volume meter from air filter housing and pull forward until the burn-off process can be observed. (Plug and vacuum hose remain connected).
- Run engine and increase speed to over 2000 rpm for at least 3 seconds.
- Switch off engine and observe burn-off process. (The hot wire glows for approx. 1 sec.).
- If the burn-off process does not take place, push back rubber grommet on plug of air volume meter. (Plug remains connected to air volume meter).

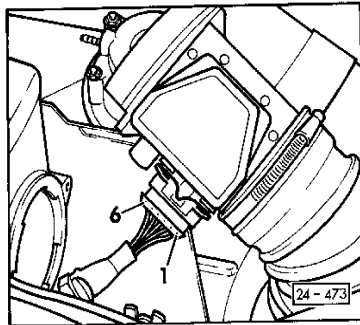

- ◀ - Connect V.A.G 1527 diode test lamp to Contact 1 and 4.
- Repeat test procedure and observe diode test lamp. The lamp should glow during the burn-off process.
- If the diode test lamp lights up, renew air volume meter.
- If diode test lamp does not light up, connect V.A.G 1598 test box with V.A.G 1598/5 adapter to Motronic control unit, see Repair Group 01.
- Connect diode test lamp to Socket 26 (earth) and Socket 25.

24-65

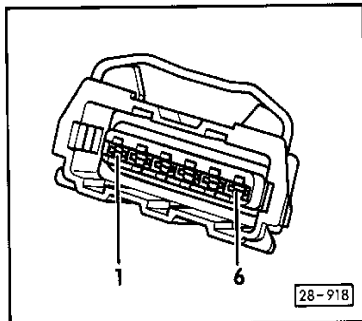

- Repeat test procedure and observe diode test lamp. The diode test lamp must light up during burn-off.
- If diode test lamp does not light up, renew control unit.
- ◀ - If diode test lamp lights up, use ohmmeter to check continuity in circuit between Contact 4 of connector at air volume meter and Socket 25 of test box. Specification, Max. 0.5 ohm.

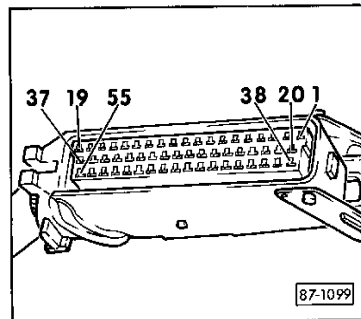

- ◀ - Where necessary, eliminate open circuit between Contact 4 of connector at air volume meter and Contact 25 of connector at Motronic control unit.

24-66

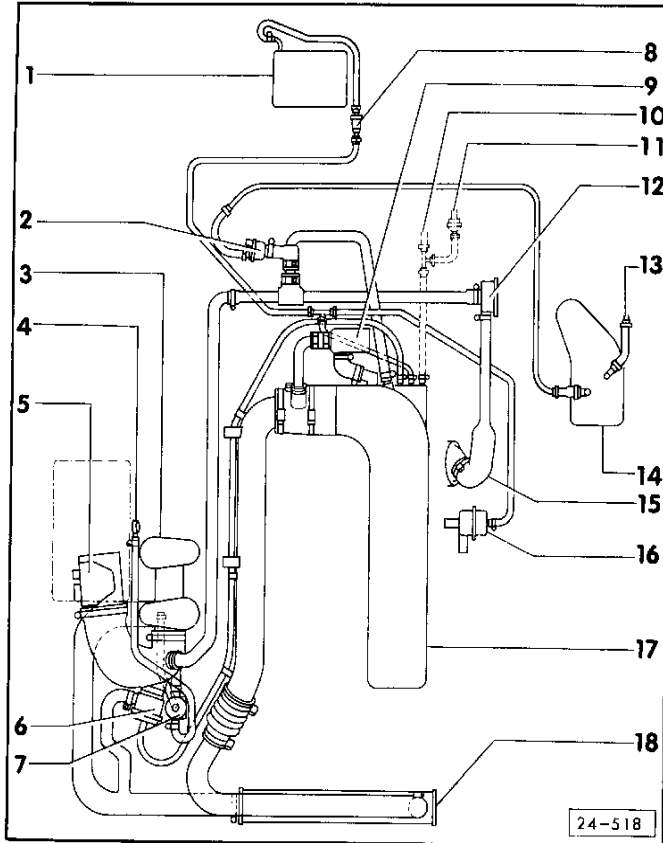

VACUUM CONNECTIONS

- 1- Motronic control unit  
• Installation location behind trim beneath glove box
- 2- Activated charcoal filter solenoid
- 3- Turbocharger
- 4- to air dump valve
- 5- Air volume meter
- 6- Overrun cut off valve  
• The overrun cut-off valve reduces boost pressure on overrun, thus providing smooth drive-off and acceleration.
- 7- Solenoid valve for boost pressure limitation
- 8- Fluid separator

24-67

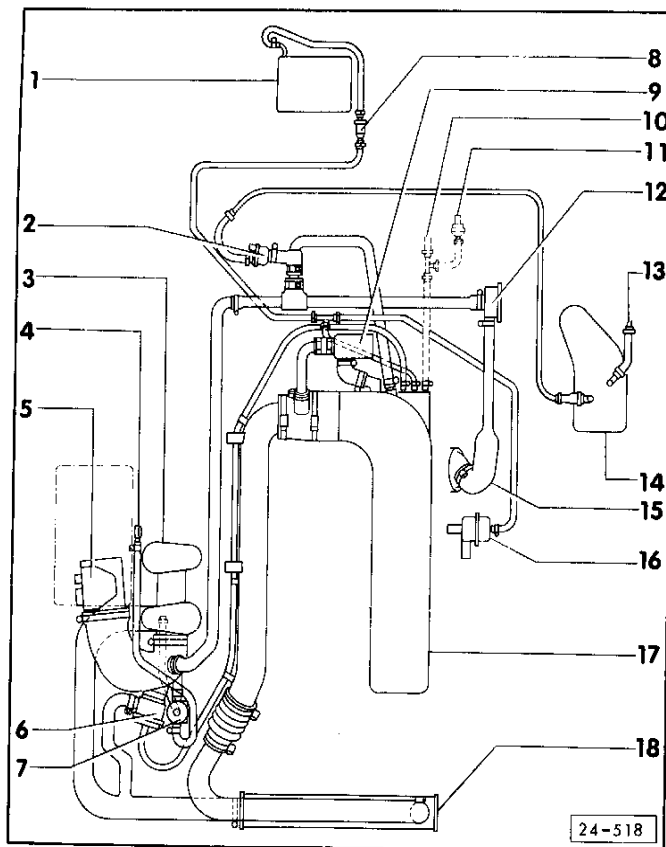

- 9- Idle speed stabilization valve
- 10- Differential lock connection
- 11- Air conditioner connection  
(vehicles with air conditioner only)
- 12- Pressure regulator valve for crankcase ventilation
- 13- from fuel tank
- 14- Activated charcoal filter
- 15- Crankcase breather
- 16- Fuel pressure regulator
- 17- Intake manifold
- 18- Intercooler

24-68

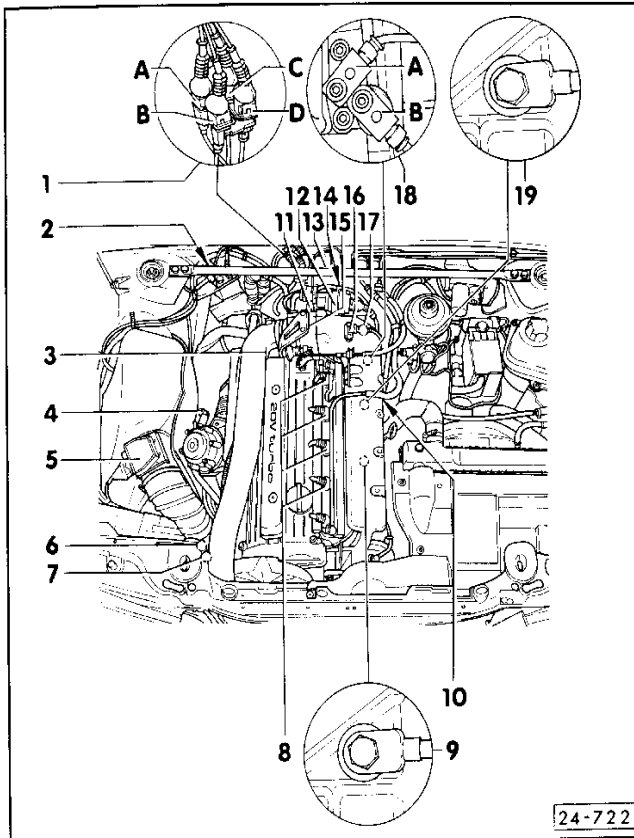

24-722

MOTRONIC COMPONENTS

1- Connection for:

- A - Front knock sensor I -G61  
(brown connector)
- B - Rear knock sensor I -G66  
(green connector)
- C - Firing point sensor -G4  
(reference point sensor, black connector)
- D - Engine speed sensor -G28  
(gray connector)

2- Connections for Lambda probe  
lambda probe heater -Z19  
(black 2-pin connector)  
lambda probe -G39  
(signal wire)

3- Coolant temperature sensor -G62  
(at right rear of cylinder head)  
• Checking - page 28-20

4- Lambda probe -G39  
• Checking - page 24-38

5- Air volume meter -G19  
• Checking - page 24-60

6- Solenoid valve for boost pressure limitation -N75  
• Checking - page 24-46

28-1

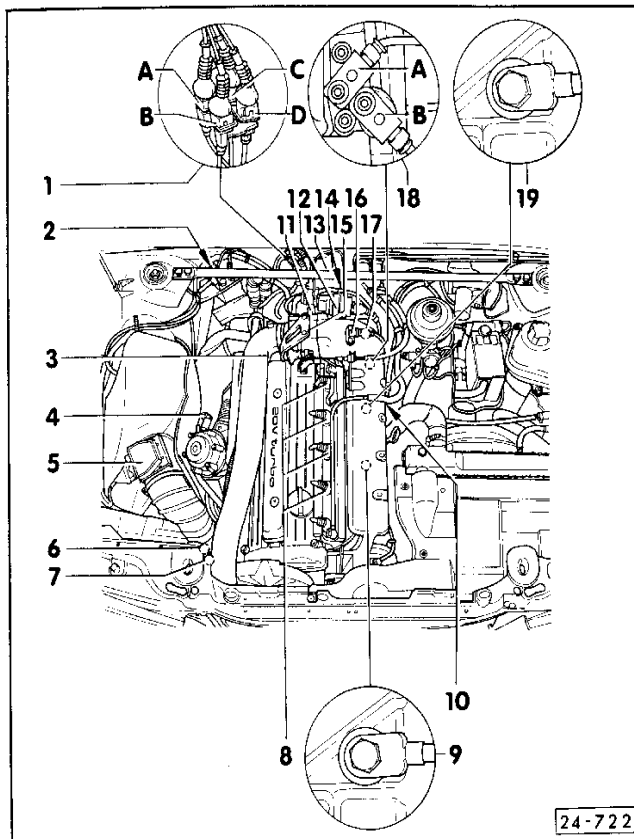

24-722

7- Overrun cut-off valve  
• Checking - Repair Group 21

8- Injectors  
• Checking - page 24-23

9- Front knock sensor I -G61

10- Fuel pressure regulator  
• Checking system and holding pressure  
- page 24-11

11- Throttle valve potentiometer -G69  
(with integral idle switch)

12- Valve for idle speed stabilization -N71  
• Checking - page 24-33

13- Ignition coil -N  
• Checking - page 28-11

14- Solenoid valve for activated charcoal filter -N80  
• Checking - page 24-42

15- Throttle valve housing

16- Intake air temperature sensor -G42  
• Checking - page 28-18

17- Distributor -0 with Hall sender -G40  
• Checking Hall sender - page 28-25  
• Basic distributor settings - page 28-27

28-2

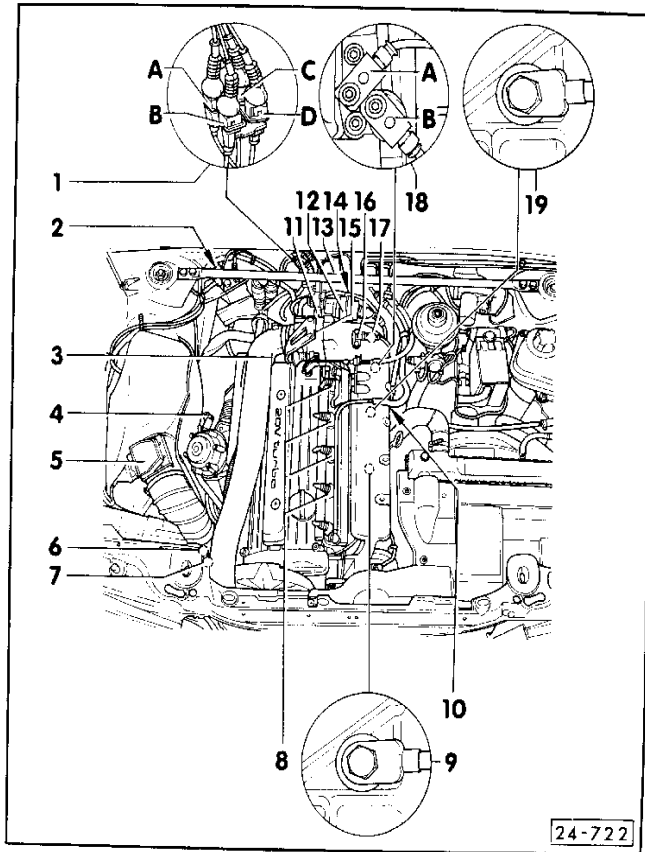

18- A - Firing point sender -G4 (reference point sensor, black connector)  
 • Checking - page 28-13

B - Engine speed sensor -G28 (gray connector)  
 • Checking - page 28-15

19- Rear knock sensor II -G66

28-3

IGNITION - TECHNICAL DATA

Engine code		38
Firing point sender**	Resistance kohms	approx. 1.0
Engine speed sensor***	Resistance kohms	approx. 1.0
** - Checking firing point sender - page 28-13		
*** - Checking engine speed sensor - page 28-15		
<u>Important!</u>		
• The ignition timing is determined by the ignition map in the control unit.		
• The ignition timing can not be adjusted.		
• The distributor is on no account to be rotated.		

28-4

Spark plugs (Tightening torque 30 Nm)	Part No. Bosch	N 101 000 016 AA F 5 DPO R
Electrode gap	mm	0.6 + 0.1
Firing order		1-2-4-5-3
Matronic rpm limitation	Cut-off speed, rpm	7200 ± 40
Ignition coil	Secondary resistance kohm Primary resistance ohm	approx. 5 - 9 approx. 0.5-1.5
Rotor arm	Resistance kohm	1.0
Ignition HT cable	Resistance kohm	1.0
Spark plug connector	Resistance kohm	5.0

28-5

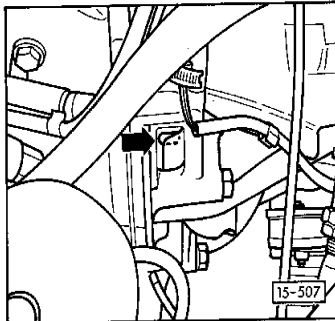

TDC mark

- ◀ - With engine fitted in vehicle align TDC mark -0- with the boss on the clutch Bell housing.

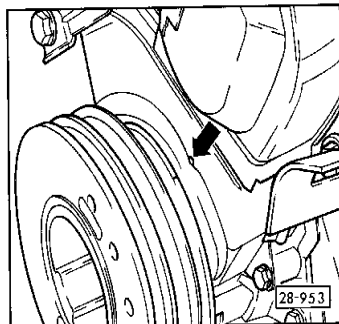

- ◀ - With engine removed from vehicle, align vibration damper notch with mark stamped on toothed belt guard.

Note:  
TDC mark with toothed belt guard removed - see Repair Group 13.

28-6

#### MOTRONIC SAFETY MEASURES

To prevent person injury and/or destruction of the Motronic control unit, the following rules are to be observed when servicing vehicles with Motronic:

##### Important!

Where a radio unit with anti-theft code is fitted, call the code before disconnecting battery earth strap.

- Ignition must be switched off for connecting and disconnecting battery, as Motronic control unit could otherwise be damaged.
  - Wait at least 20 sec. after switching off ignition before removing plug from Motronic control unit as Motronic control unit could otherwise be damaged.
- 
- Do not touch or remove ignition cables when engine is running or starter is operating.
  - Only detach ignition system wiring when ignition is switched off.
  - Only attach and detach measuring equipment cables (engine speed - ignition tester) when ignition is switched off.
  - Do not attach either a suppression capacitor or a test lamp to Terminal 1 of the ignition coil.

28-7

- If the engine is to be turned over at starter speed (e.g., compression testing, Motronic test), remove both 3-pin plug from the coil output and the plugs from all 5 injectors.
- The ignition coil is not to be replaced by a conventional coil.
- Do not disconnect battery with engine running.
- Do not attempt to simulate output signals by applying voltage to control unit.
- Do not activate starter with injectors removed.

28-8

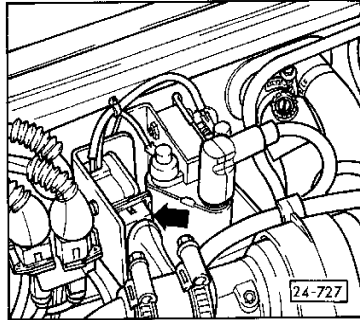

CHECKING IGNITION SYSTEM POWER OUTPUT STAGE -  
N70

Checking control signal to power output stage

- \* - Detach plug from the power output stage of ignition coil.

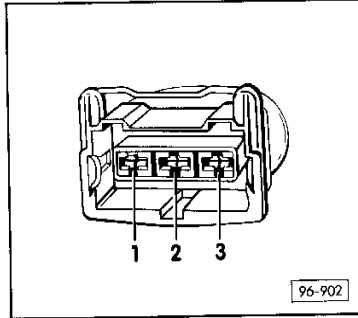

- \* - Measure voltage by connecting V.A.G 1526 hand multimeter and auxiliary lead on V.A.G 1594 between Contact 1 and earth, and then Contact 1 and 3.
- Switch off ignition.
- Specification: Approx. 12 volts each.
- If specified voltage is not achieved, consult CFD to eliminate open circuit.

28-9

- Measure voltage by switching V.A.G 1526 hand multimeter with auxiliary lead from V.A.G 1594 between Contact 2 and 3.

- Crank engine with starter.

- Specification: At Least 0.2 volts.

- If specified reading is not obtained, connect V.A.G 1598 test box with V.A.G 1598/5 adapter to wiring only at Motronic control unit - see Repair Group 01.

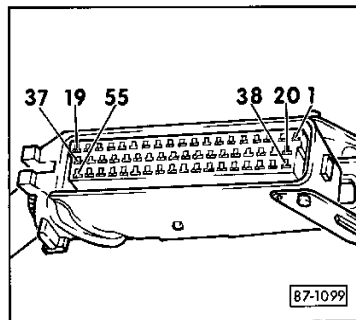

- Check wiring between Contact 2 of power output stage connector and Socket 1 of test box for continuity or short to earth. Specification: Max. 1.0 ohm

- \* - Where necessary, eliminate open/short circuit between Contact 2 of power output stage plug and Contact 1 connector at Motronic control unit.

- If no open circuit or short circuit to earth is detected, renew Motronic control unit.

28-10



#### CHECKING IGNITION COIL -N

##### Note:

Check wire between power output stage and ignition coil and wire between power output stage and engine for corrosion and damage to insulators.

- Remove 3-pole plug from ignition coil power output stage.
- Remove plug from Terminal 4 of ignition coil (ignition wires).
- Remove rubber caps from screw connections of ignition coil.

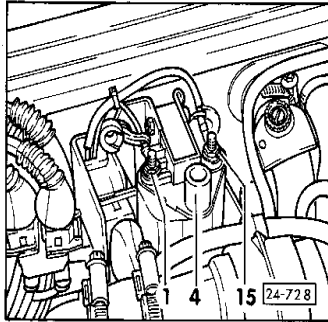

##### Checking secondary resistance

- Use V.A.G 1526 hand multimeter with auxiliary lead from V.A.G 1594 to measure resistance between Terminal 1 and 4 of ignition coil.
- Specification: 5 - 9 kohms.
- If the specified value is not achieved, renew ignition coil.

28-11

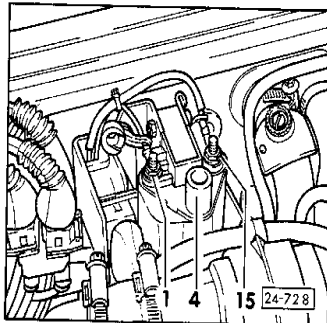

##### Checking primary resistance

- Use V.A.G 1526 hand multimeter with auxiliary lead from V.A.G 1594 to measure resistance between Terminal 1 and 15 of ignition coil.
- Specification: 0.5 - 1.5 ohm.
- If specified value is not achieved, renew ignition coil.
- If the engine fails to run, although the readings are correct when checking the ignition coil with power output stages, check distributor cap, rotor arm and the ignition wiring for damage. If no damage is found, renew ignition coil if necessary.

28-12

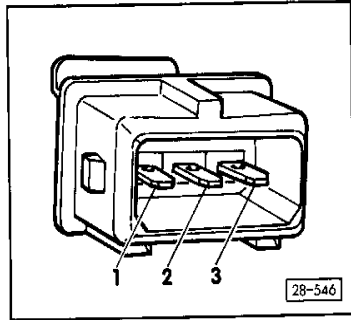

#### CHECKING FIRING POINT SENDER -G4

Installation position of sender and plug connections, see page 28-3.

- Separate connector for firing point sender (identification: black connector).
- ◀ - Measure resistance by connecting V.A.G 1526 hand multimeter with auxiliary lead V.A.G 1594 to Contact 1 and 2.
- Specification: Approx. 1 kohm
- If specified value is not achieved, renew firing point sender.
- If specification is achieved, connect hand multimeter to Contact 1 and 3 and to Contact 2 and 3.
- Specified reading: infinite ohms in each case (no continuity).
- If specified reading is not obtained, renew firing point sender.
- If specified reading is obtained, check circuit between sender coupling and Motronic control unit as follows:

28-13

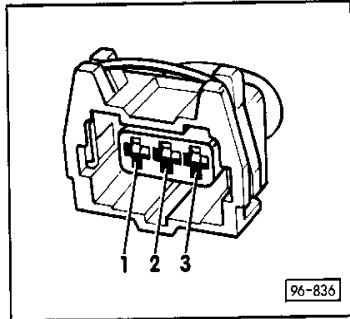

- Connect V.A.G 1598 test box with V.A.G 1598/5 adapter at wiring loom only at Motronic control unit - see Repair Group 01.
- ◀ - The following wires should be checked for continuity or short circuits using an ohmmeter CFD:
  - From sender coupling Contact 1 to Socket 28
  - From sender coupling Contact 2 to Socket 49
  - From sender coupling Contact 3 to Socket 19 (earth)

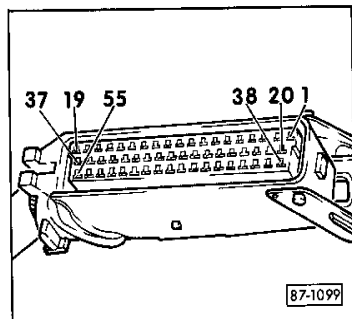

- ◀ - If necessary, eliminate open circuit or short circuit in wires between sender coupling and plug for Motronic control unit Contact 48/49 and 19.
  - If no fault has been detected up to now, check pin for sender on ring gear:
- To check pin, holder with firing point sender and engine speed sensor must be removed.
- Turn the engine until the pin appears in the opening.

28-14

- Check condition of pin (damage/bent) and that the pin is securely located, renew if necessary.
- If no faults have been detected in testing up to now, renew Motronic control unit.

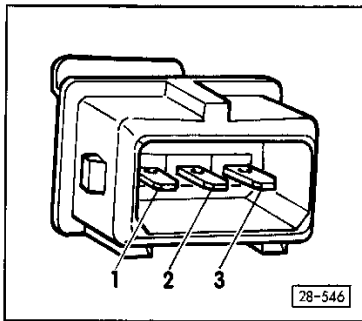

#### CHECKING ENGINE SPEED SENSOR -G28

Installation position of sensor and plug connections - see page 28-3.

- Remove plug from engine speed sensor (identification: gray connector).
- Measure resistance by connecting V.A.G 1526 hand multimeter with auxiliary lead from V.A.G 1594 to Contact 1 and 2.
- Specified reading: Approx. 1 kohm.
- If specified reading is not obtained, renew engine speed sensor.
- If specified reading is obtained, connect ohmmeter to Contact 1 and 3 and to Contact 2 and 3.

28-15

- Specified reading: infinite ohms in each case (no continuity).
- If specified reading is not obtained, renew engine speed sensor.
- If specified reading is obtained, check wiring between sender coupling and Motronic control unit as follows:
  - Connect V.A.G 1598 test box with V.A.G 1598/5 adapter to wiring loom only at Motronic control unit - see Repair Group 01.

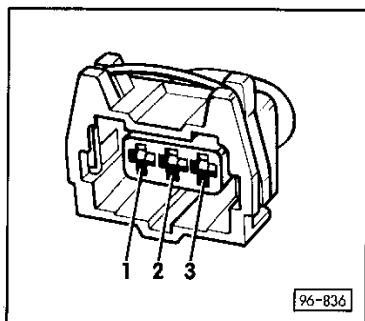

- Consult CFD to check the following wires for continuity and short circuit to one another:
  - From sender coupling Contact 1 to Socket 48
  - From sender coupling Contact 2 to Socket 47
  - From sender coupling Contact 3 to Socket 19 (earth)

28-16

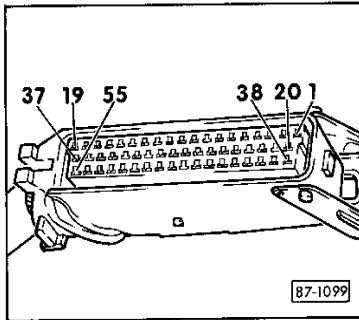

- Where necessary, eliminate open/short circuit in wiring between sender coupling and connector for Motronic control unit (Contact 47/28 and 19).

- If no faults have been detected until now, check the teeth on the starter ring gear.

The holder with engine speed sensor and firing point sender must be removed in order to check the teeth.

- Rotate engine slowly and examine ring gear for concentricity and broken or damaged teeth, renew where necessary.
- If no faults have been detected up to now in testing, renew Motronic control unit.

28-17

#### CHECKING INTAKE AIR TEMPERATURE SENSOR -G42

Installation location of intake air sensor - see page 28-2.

- Engine cooled to room temperature. (Approx. 20°C).
- Connect V.A.G 1598 test box with V.A.G 1598/5 adapter to wiring loom only at Motronic control unit - see Repair Group Q1.
- Measure resistance by connecting V.A.G 1526 hand multimeter with auxiliary lead from V.A.G 1594 to Socket 30 and 44.
- Specified reading: 450 - 650 ohms.
- If specified reading is not obtained, push back rubber grommet on intake air temperature sensor.
- Connect hand multimeter between contacts on sensor.
- Specified reading: Approx. 450 - 650 ohms.
- If specified reading is not obtained, renew intake air temperature sensor.
- If specified reading is obtained, check wiring between sensor and control unit as follows:
- Connect hand multimeter to Socket 30 of test box and then, consecutively, to both contacts of the sensor.

28-18

- Specified reading: Approx. 0 ohms (continuity) or approx. 450 - 650 ohms.
- This check should be repeated at Socket 44 of the test box.
- If the specified readings are not obtained, consult CFD to eliminate open/short circuit.

#### RENEWING AIR INTAKE TEMPERATURE SENSOR -G42

- Push back rubber grommet on intake air temperature sensor.
- Remove intake air temperature sensor.
- Cut wires from sensor and remove rubber grommet.
- Push on new rubber grommet, and fit shrink-to-fit sleeves to both wires.
- Attach wire terminals to the stripped wire ends and attach to the sensor.
- Carefully solder both wire terminals to sensor. (Sensor must not become too hot).

#### Important!

Solder from the terminals must not come in contact with the braided section as this could become a fracture point.

- Push shrink-to-fit sleeves over the solder joints and heat.
- Push on rubber grommet and install sensor.

28-19

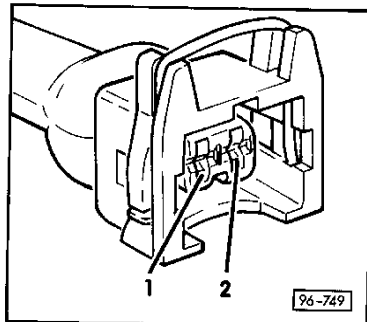
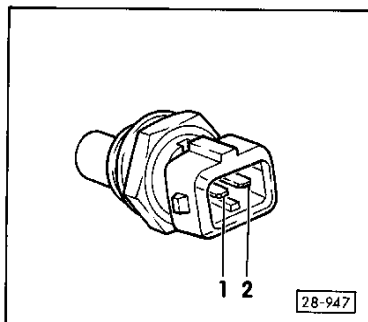

#### CHECKING COOLANT TEMPERATURE SENSOR-G62

Installation location of coolant temperature sensor - see page 28-1.

- \* Engine cooled to room temperature (approx. 20°C).
- Remove connector from coolant temperature sensor.
- \* - Measure resistance by connecting V.A.G 1526 hand multimeter with auxiliary lead from V.A.G 1594 to Contact 1 and 2 of sensor.
- Specified reading: Approx. 1.5 - 3.0 kohms.
- If specified reading is not obtained, renew sensor.
- If specified reading is obtained, check circuit between sensor and Motronic control unit as follows:
  - Connect V.A.G 1598 test box with V.A.G 1598/5 adapter to wiring loom only at Motronic control unit - see Repair Group 01.
- \* - Check circuit continuity between Socket 45 and Contact 2 of connector at sensor for coolant temperature. Specified reading: Max. 1.0 ohm.
- Check circuit continuity between Socket 30 and Contact 1 of connector for coolant temperature sender. Specified reading: Max. 1.0 ohm.
- Check for short circuiting between the two wires.

28-20

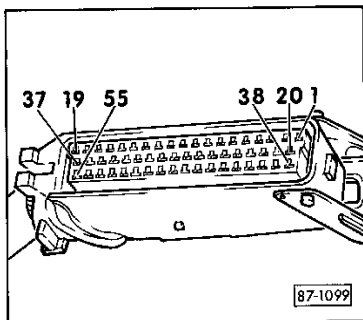

- ◀ - Where necessary, consult CFD to eliminate short/open circuit between plug at sensor and connector at Motronic control unit.
- If testing has uncovered no faults up until now, renew control unit.

#### CHECKING VOLTAGE SUPPLY TO MOTRONIC CONTROL UNIT

- Check Fuse 27.
- Connect V.A.G 1598 test box with V.A.G 1598/5 adapter to wiring loom only at Motronic control unit - see Repair Group 01.
- Connect V.A.G 1527 diode test lamp to Socket 18 (permanent positive) and then consecutively to Socket 10, 14, 19 and 24 (earth connections).
- The diode test lamp must light up each time.
- Should the diode test lamp fail to light up, consult CFD to eliminate open circuit.

28-21

#### CHECKING KNOCK SENSORS -G61 AND -G66

##### Note:

- Electrical testing of knock sensor is not possible.
- Recall fault memory - see Repair Group 01.
- Knock sensors must be tightened to the specified 20 Nm precisely, as sensor operation could otherwise be impaired.
- Check plug connector from knock sensor to wiring loom for corrosion.

#### Checking knock sensor wires

- Disconnect plug of knock sensor being tested in engine compartment (installation location of plug connectors - page 28-1).

28-22

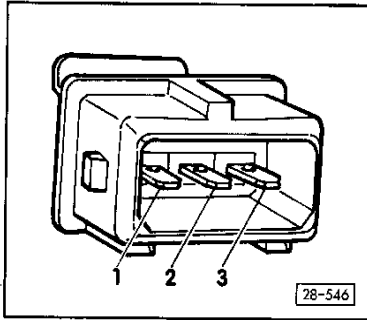

- ◀ - Check all three contacts at plug of knock sensor for short circuits to one another. There should be no connections between the wires.
- If a connection is present, renew knock sensor.

Checking circuit between knock sensors and Motronic control unit

- Connect V.A.G 1598 test box with V.A.G 1598/5 adapter to wiring loom only at Motronic control unit - see Repair Group 01.
- Separate plug connectors of the two knock sensors in the engine compartment (installation position of plug connectors page 28-1).

28-23

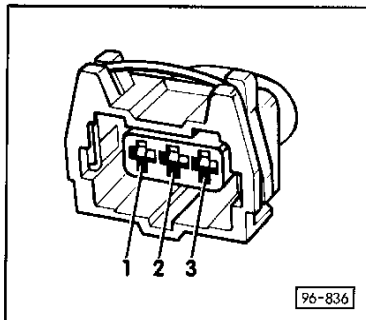

- ◀ - Consult CFD to check the following wires for continuity and short circuiting to one another:
  - From green sensor coupling, Contact 1 to Socket 29 (signal wire)
  - From green sensor coupling, Contact 2 to Socket 30 (sensor earth wire to control unit)
  - From green sensor coupling, Contact 3 to Socket 19 (screening to earth)
  - From brown sender coupling, Contact 1 to Socket 11 (signal wire)
  - From brown sender coupling, Contact 2 to Socket 30 (sensor earth wire to control unit)
  - From brown sensor coupling, Contact 3 to Socket 19 (screening to earth)
- Continuity - Specified reading: Max. 1.0 ohm.
- Short circuit - Specified reading: infinite ohms.

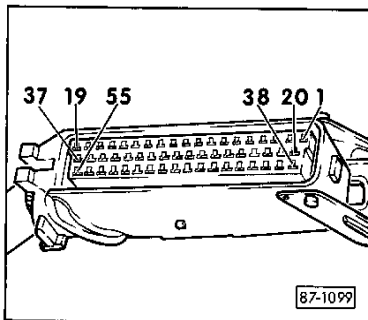

- ◀ - Where necessary, eliminate short/open circuit in circuit between sensor coupling in question and connector at Motronic control unit Contact 11/29, 30, 19.

**Important!**  
Only gold contacts are to be used for repairing contact in connectors for knock sensors.

28-24

#### CHECKING HALL SENDER -G40

The Hall sender is located in the distributor - see page 28-2, position 17.

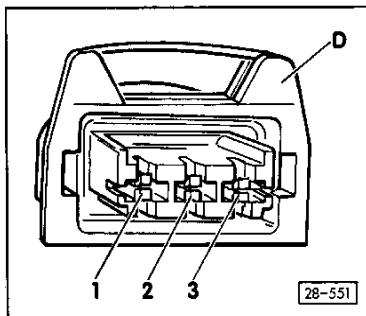

- Connect V.A.G 1598 test box with V.A.G 1598/5 adapter to Motronic control unit (see Repair Group 01).
- Connect V.A.G 1527 diode test lamp to Socket 8 and 12.
- Operate starter for a few seconds.
- The diode test lamp must flash briefly at every second revolution.
- Should the diode test lamp fail to blink, switch off ignition and remove 3-pin plug for Hall sender at distributor.
- ◀ - Consult CFD to check the following wires for continuity and short circuit:
  - From connector for Hall sender, Contact 1 to Socket 19
  - From connector for Hall sender, Contact 2 to Socket 8
  - From connector for Hall sender, Contact 3 to Socket 12
- Continuity - Specified reading: Max. 1.0 ohm.
- Short circuit - Specification: infinite ohms.

28-25

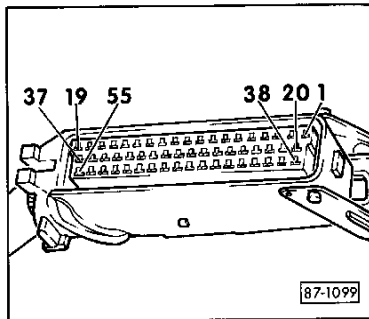

- ◀ - Where necessary, eliminate open/short circuit between connector for Hall sender and connector for Motronic control unit (Contact 12, 8 and 19).
- If no short or open circuit is present, switch on ignition.
- Measure voltage by connecting V.A.G 1526 hand multimeter with auxiliary lead from V.A.G 1594 to Socket 12 and 19.
- Specified reading: 4.5 - 5.5 volts.
- Connect V.A.G 1526 hand multimeter to Socket 8 and 19.
- Specified reading: 4.3 - 5.2 volts.
- If specified readings are not obtained, renew Motronic control unit.
- If specified readings are obtained, renew ignition distributor. (Removing and installing distributor - see "Basic distributor adjustment", page 28-27).

28-26



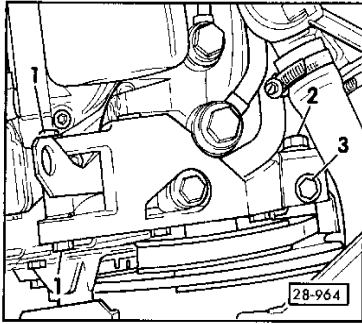

**BASIC DISTRIBUTOR ADJUSTMENT**  
 (Only required if fault code 2113 is indicated  
 or if distributor is removed)

- Switch off ignition.
- Remove upper radiator cowling.
- ◀ - Slacken both retaining bolts -1- for hydraulic pump.
- ◀ - Unscrew nut -2- on tensioner, turn screw -3- to slacken V-belt.
- Remove V-belt.
- Remove retaining bolts -1- and tilt hydraulic pump toward the left.
- ◀ - Remove earth wires and vacuum unit for cruise control system (CCS) from intake manifold.

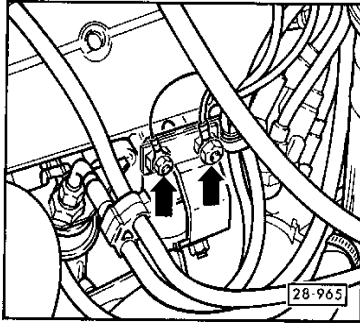

28-27

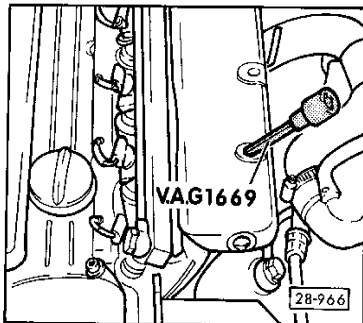

- ◀ - Remove intake manifold from cylinder head, use V.A.G 1669 socket attachment.
- Remove plug connections from injectors.
- Bolt vacuum unit for speed control system loosely to intake manifold without bracket or wiring harness.

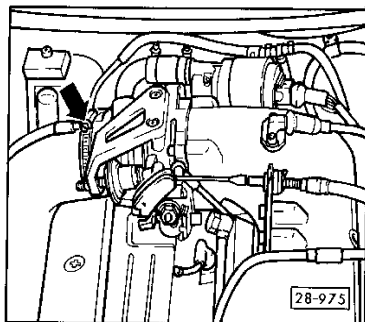

- ◀ - Loosen hose clamp at intake pipe (arrow).

28-28

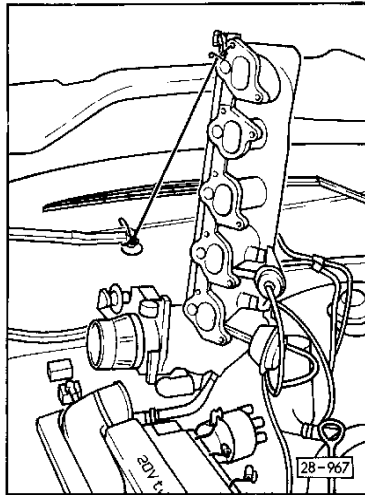

- ◀ - Lift up intake manifold with throttle valve housing, idle stabilization valve and CCS unit and attach to windscreen wiper arm with a suitable length of wire as shown.

**Important!**

- Bend over wire ends to avoid injury!
- Do not scratch wiper arm!
- Ignition must be switched off.

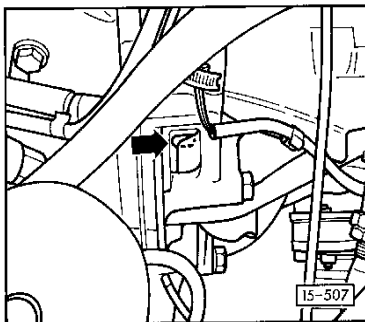

- ◀ - Engage fifth gear and push vehicle until crankshaft lines up at TDC.
- Unscrew both retaining bolts for upper toothed belt guard, and push toothed guard forward until marks on camshaft sprocket are visible.

28-29

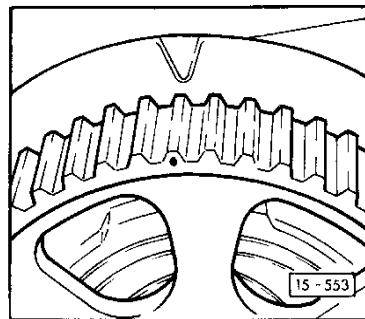

- ◀ - Inspect marking on camshaft sprocket: The marking must be aligned with the marking on the cylinder head cover.

**Note:**

- If the marking is 180° out of alignment, turn the engine one complete revolution until the crankshaft is again at the TDC position.
- If the markings are not aligned, this means that the tooth belt has jumped out of position - see Workshop Manual, Repair Group 13, Installing toothed belt.

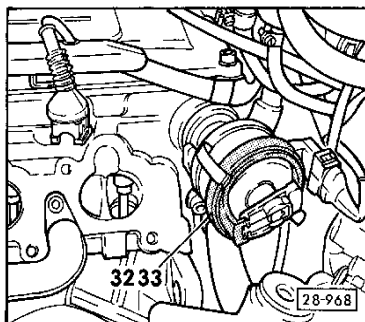

- Remove distributor cap.

**Note:**

- Take care that rotor does not scratch inside of distributor cap during removal and installation.

- ◀ - Fit adjuster gauge 3223 on distributor so that the locating nut on the adjuster gauge engages on the distributor housing and the distributor engages in the recess of the gauge.

- If the distributor rotor does not engage in the adjuster gauge, slacken the distributor mountings (remove tamper-proof cover if necessary) and turn distributor until rotor engages.

28-30

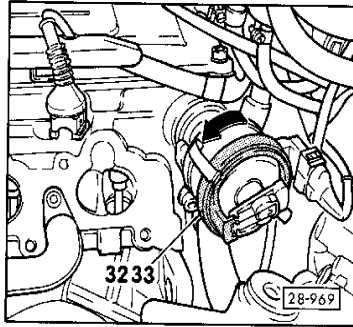

Note:

It is not necessary to reinstall the tamper-proof cover.

- ◀ - Tighten distributor mounting while pressing distributor in direction of arrow by hand.
- Remove adjustor gauge 3233 and turn rotor gently to ascertain whether distributor shaft moves freely - it must be possible to feel gear play.
- If ignition distributor shaft is jammed, remove distributor and place two, a maximum of three gaskets between distributor and cylinder head. Check axial clearance of distributor. Axial clearance is not to exceed 0.3 mm. If clearance is greater, renew distributor. Where play in the drive is excessive, check the drive pinion teeth.

Note:

If the drive pinion teeth are damaged or sheared, the following checks should be carried out:

- Check drive chain of intake camshaft for excessive stretching - Repair Group 15.
- Check tension of toothed belt, adjust where necessary.
- Check vibration damper at front of crankshaft (cracks or distortion of rubber seal), replace vibration damper as required.

28-31

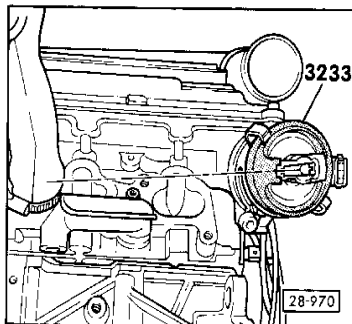

With distributor removed:

- Attach distributor gauge 3233 on distributor as described on page 28-30.
- Renew seal.
- ◀ - Place distributor in cylinder head so that distributor rotor faces forward toward water pipe.
- Retain distributor manually as described on page 28-31 and tighten.
- Remove adjustor gauge and check free movement of distributor shaft as described on page 28-31.
- Reinstall distributor cap.

Note:

- Take care that rotor does not scratch inside of distributor cap during removal and installation.
- Reinstall intake manifold, hydraulic pump and CCS unit in reverse sequence.
- Renew gasket for intake manifold flange.

Tightening torques:

- Intake manifold bolts: 25 Nm
- Hydraulic pump bolts : 25 Nm
- Bolts for CCS unit : 25 Nm

Important:

The CCS rod must not lie against the distributor.

28-32

#### IGNITION CABLE ROUTING

The ignition cables must be routed so as not to cross, as incorrect routing can influence sensor signals, resulting in ignition miss.

#### Note:

- To avoid interference, avoid attaching or routing other electrical wiring at or in immediate vicinity of ignition cables.